

HEALTH AND SAFETY

Stay informed on Products, Services and Resources that will help you plan for a safe return to your next event. [Click Here](#) for our Health and Safety Resources.

BOOTH EQUIPMENT

Each booth will be set with 8' high black back drape and 3' high black side drape. Booths 300 sqft or less will receive (1) 7" x 44" one-line booth identification sign. Booths larger than 300 sqft may receive a 7" x 44" one-line booth identification sign upon request

EXHIBIT HALL CARPET

All aisles and booths will be carpeted

DISCOUNT PRICE DEADLINE DATE

Order early on [FreemanOnline](#) to take advantage of advance order discount rates, place your order by May 04, 2021.

EXHIBITOR FREQUENTLY ASKED QUESTIONS

For more information and helpful hints on products and services, ordering and invoicing, shipping your freight, and other top questions, please visit [FreemanOnline FAQ page](#).

SHOW SCHEDULE

EXHIBITOR MOVE-IN

Tuesday June 01, 2021 9:00 AM - 5:00 PM

EXHIBIT HOURS

Wednesday June 02, 2021 9:00 AM - 4:00 PM

Thursday June 03, 2021 9:00 AM - 4:00 PM

Friday June 04, 2021 9:00 AM - 4:00 PM

EXHIBITOR MOVE-OUT

Friday June 04, 2021 6:00 PM - 8:00 PM

EXHIBITOR SERVICE HOURS

Our Exhibitor Services team will be available from 8am - 5pm from the first day of Exhibitor Move-in to the last day of Exhibitor Move-out. Hours may be extended the day before show open and the day of show close to assist with additional exhibitor needs.

DISMANTLE AND MOVE-OUT INFORMATION

All exhibitor materials must be removed from the exhibit facility by Friday, June 04, 2021 at 8:00 PM.

To ensure all exhibitor materials are removed from the exhibit facility by the Exhibitor Move-Out deadline, please have all carriers check-in by Friday, June 04, 2021 at 6:00 PM.

POST SHOW PAPERWORK AND LABELS

Our Exhibitor Support Department will gladly prepare your outbound Material Handling Agreement and labels in advance. Complete the Outbound Shipping form and your paperwork will be available at show site. Be sure your carrier knows the company name and booth number when making arrangements for shipping your exhibit at the close of the show.

EXCESSIVE TRASH AND BOOTH ABANDONMENT

Any excessive trash which consists of display materials, carpet, padding, crates and/or pallets will be disposed of and charged both a handling fee and disposal fee during move-in. Excessive booth materials and/or literature left in the booth at the end of the published exhibitor move-out that is not labeled for an outbound shipment will be considered abandoned and deemed as trash. The exhibitor will be charged for the removal and disposal of these items. Charges may include Installation & Dismantle Labor, Forklift/Rigging Labor, and/or Dumpster Fee. Please call our Exhibitor Support Department at (888) 508-5054 for a quote.

SERVICE CONTRACTOR CONTACTS / INFORMATION:

FREEMAN
(888) 508-5054
ExhibitorSupport@freeman.com

FREEMAN EVENT TECHNOLOGY
(800) 868-6886
EventTechServices@freeman.com

FREEMAN EXHIBIT TRANSPORTATION

(800) 995-3579 Toll Free US & Canada or +1 (512) 982-4187 or +1 (817) 607-5183 Local & International Shipping Services or fax +1 (469) 621-5810 or email exhibit.transportation@freeman.com

FREEMAN ONLINE®

Take advantage of discount pricing by ordering online at [FreemanOnline](#) by May 04, 2021.

Using the enhanced Freeman Online, you will enjoy easy access to added features and functions as well as the high caliber of Freeman services you've come to expect - **before, during** and **after** your show.

To place online orders you will be required to enter your unique Username and Password. If this is your first time to use Freeman Online, click on the "**Create an Account**" link. To access Freeman Online without using the email link, visit [FreemanOnline](#).

If you need assistance with Freeman Online please call Exhibitor Support at (888) 508-5054 Toll Free US & Canada or +1 (512) 982-4186 or +1 (817) 607-5000 Local & International.

SHIPPING INFORMATION

Warehouse Shipping Address:

Exhibiting Company Name / Booth # _____

NEW CARDIOVASCULAR HORIZONS CONFERENCE

C/O FREEMAN

905 SAMS AVE,

NEW ORLEANS, LA 70123

Freeman will accept crated, boxed or skidded materials beginning Monday, May 17, 2021, at the above address. Material arriving after May 26, 2021 will be received at the warehouse with an additional after deadline charge. Please note that the Freeman Warehouse does not accept uncrated freight (loose, pad-wrapped material and/or unskidded machinery), COD shipments, hazardous materials, freight requiring refrigerated or frozen storage, a single piece of freight weighing more than 5,000 pounds or a single piece of freight beyond the dimensions of 108" H x 93" W. Warehouse materials are accepted at the warehouse Monday through Friday between the hours of 8:00 AM - 3:30 PM. Certified weight tickets must accompany all shipments. If required, provide your carrier with this phone number: (888) 508-5054.

Show Site Shipping Address:

Exhibiting Company Name / Booth # _____
NEW CARDIOVASCULAR HORIZONS CONFERENCE
 C/O FREEMAN
 ROOSEVELT HOTEL
 116 UNIVERSITY PL
 NEW ORLEANS, LA 701122502

Freeman will receive shipments at the exhibit facility beginning Tuesday, June 01, 2021. Shipments arriving before this date may be refused by the facility. Any charges incurred for early freight accepted by the facility are the responsibility of the Exhibitor. Certified weight tickets must accompany all shipments. If required, provide your carrier with this phone number: (888) 508-5054.

Please note: All materials received by Freeman are subject to Material Handling Charges and are the responsibility of the Exhibitor. This also applies to items not ordered through the Official Show Vendors. Refer to the material handling form for charges for the service.

Please be aware that disposal of exhibit properties is not included as part of your material handling charges. Please contact Freeman for your quoted rates and rules applicable to disposal of your exhibit properties.

PURCHASE TERMS

Freeman's Terms & Conditions apply to all orders submitted to Freeman for any goods or services, and may be amended without notice. To review the current Purchase Terms, [click here](#).

LABOR INFORMATION

Union Labor may be required for your exhibit installation and dismantle. Please carefully read the UNION RULES AND REGULATIONS to determine your needs. Exhibitors supervising Freeman labor will need to pick up and release their labor at the Freeman Service Center. Refer to the order form under Display Labor for Straight time and Overtime hours.

ASSISTANCE

We want you to have a successful show. If we can be of assistance, please call Exhibitor Support at (888) 508-5054.

WE APPRECIATE YOUR BUSINESS!

FREEMAN GENERAL INFORMATION

TRANSLATION SERVICES

Freeman is pleased to offer a new service for our international exhibitors that provides quick interpretation and translation in 150 languages. This service will not only interpret for us on a three way conversation, but also translate emails from customers. To access this feature you may contact Exhibitor Support at (888) 508-5054 US & Canada or +1(817) 607-5000 Local & International.

HELPFUL HINTS

SAVE MONEY

Order early on [FreemanOnline](#) to take advantage of advance order discount rates, place your order by May 04, 2021.

AVOID DELAY

Ship early to avoid delays. Shipments arriving late at show site will cost you money, time and business!

SAFETY TIPS

Use a ladder, not a chair. Standing on chairs, tables and other rental furniture is unsafe and can cause injury to you or to others. These objects are not designed to support your standing weight.

Be aware of your surroundings. You are in an active work area with changing conditions during move-in and move-out. Pay attention. Look for obstacles, machinery and equipment that are in use.

Keep your eyes open for scooters and forklifts. The drivers of these vehicles may not be able to see you.

Stay clear of dock areas, trucks and trailers. These areas can be particularly dangerous.

Prevent electrical shocks, falling items and damage to materials. Do not attach items or equipment to the drapes or metal framework provided for your booth. This can cause serious injury or damage to materials.

We discourage children from being in the exhibit hall during installation and dismantle. If children are present during installation and dismantle, they must be supervised by an adult at all times.

Freeman does not ship or handle Hazardous Materials. If any materials you are shipping to the event fall into this category, please contact Freeman to be sure the material will be allowed at the facility and by the association. In addition, if authorized by the facility and the association, you will need to make separate arrangements for the transport and handling of the approved materials, since Freeman will not transport or handle them.

The operation or use of all motorized lifts and motorized material handling equipment for installation/dismantle of exhibits is NOT permitted by exhibitors or by their exhibitor appointed contractors (EACs). Thank you for your cooperation.

Call Exhibitor Support at (888) 508-5054 with any questions or needs you may have.

Interested in going green and saving money?

Follow these tips to make sure your sustainable booth strategies are cost-neutral or even cost-saving! Leave an impact on the show floor, not the environment.



1 BEFORE THE SHOW

booth structure

Option 1 Multiple Use

Use **Forest Sustainable Certified (FSC)** wood to build your booth and crates.

Get creative! Design your booth with a **small shipping footprint** to minimize carbon emissions. Freeman's eye-catching stretch-fabric booth designs pack up small (and light!) for shipping.

Option 2 One-time Use

Rent locally from nearby Freeman offices to reduce both shipping costs and carbon emissions.

2 carpet

Option 1 Rent

Rent rather than buy carpet to save on shipping, cleaning, and storage. Freeman Classic carpet can be reused at least four times.

Option 2 Color

Use darker-colored carpet, which is easier to reuse and recycle. Freeman Classic dark-colored carpets are made of 20-50 percent recycled content.



3 shipping

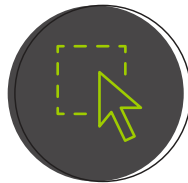

Online + before deadline = better bottom line. Take advantage of early-bird pricing and consolidate shipping when ordering supplies.

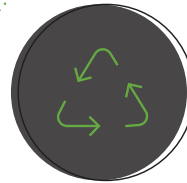

Choose reusable shipping padding. Avoid packing peanuts and foam plastic materials that never decompose.



Ship early. Use the 30-day policy to ship materials to the Freeman advance warehouse.

4 graphics

Option 1 Multiple Use

Print on a durable substrate **without dates, event names, or locations.**

Option 2 One-time Use

Print on 100 percent recyclable materials like Freeman Honeycomb and Smartbuild Eco, which are just as cost-effective as PVC.

5 printing



Reduce printing and **go digital** with your booth literature.



Print locally. Supporting local businesses while reducing shipping? It's a win-win.



Print on at least **50 percent post-consumer recycled paper.**

6

ON SITE

save energy



Use Energy Star-rated equipment for audio-visual equipment and monitors.



Power down. Turn off equipment at the end of each day.



Light up your booth with CFLs, LEDs, or other energy-efficient lighting.

8

shipping out

Pack in, pack out.

Leave no traces on show site.

Join a caravan.

If you're shipping directly to another show, ask **Freeman Transportation about joining a caravan** to your next show.

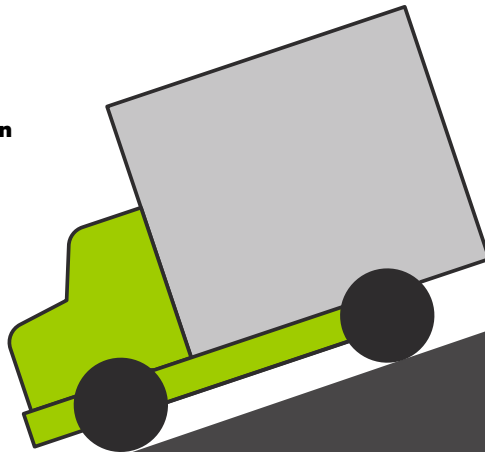

9

leftover materials

Remember to label.

Clearly **label recyclable leftover material** for disposal.

Donate the rest.

Ask the Freeman Exhibitors Services desk about local donation programs.

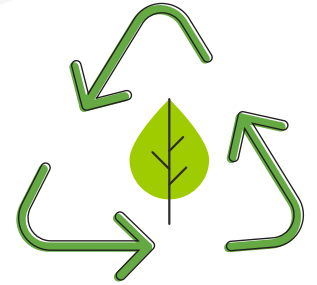

TYPICALLY* DONATE-ABLE

Furniture: Purchased items
Home furnishing: Décor staging materials

Unused raw materials: Plywood, subflooring, non-laminate wood

Flooring: 100 square feet of flooring. Excludes carpet.

Left over giveaways: Pens, pads of paper, sunglasses, USBs, etc., left over in your promotional giveaway

TYPICALLY* RECYCLABLE

Cardboard: Used for signs or shipping boxes

Glass: Green, brown, clear

Plastics: Shrink-wrap or plastic banding used to secure shipments; water/soda bottles; plexiglass (acrylics) clear, smoked, or tinted; Visqueen used to protect flooring

Metal: Aluminum cans/ steel banding

Paper: Fliers, brochures, programs, tickets, office paper, newspaper, magazines, paperboard

Wood: Non-laminate wood

Payment Information

Freeman only accepts payment information electronically. Place your order on FreemanOnline or follow the steps below to provide your payment information electronically and submit your order forms.
Freeman will no longer accept cash payments for any Freeman Services.

1. Submit your payment information

Proceed to our electronic Freeman Pay site to securely submit your payment information
<https://www.freemanpay.com/505640>

2. Submit your order

Upload your order forms through the same link used to submit your payment information

- **Both your order and your payment must be received by the discount deadline date to guarantee discount pricing.**
- **Orders received without payment or after the discount price deadline date will be charged at the standard price.**
- **Copies of invoices may be picked up from the Freeman Service Center prior to show closing.**

before event

during the event

after event

from your location
or previous event

to your location
or next event

event venue

venue
dock

your exhibit

venue
dock

advance
warehouse

storage for empty containers



advance warehouse

where exhibit materials are stored before an event



shipping

transport to the venue's shipping dock then from the shipping dock to the next event or customer location



material handling

move items from the dock, to the exhibit, back to the dock after the show

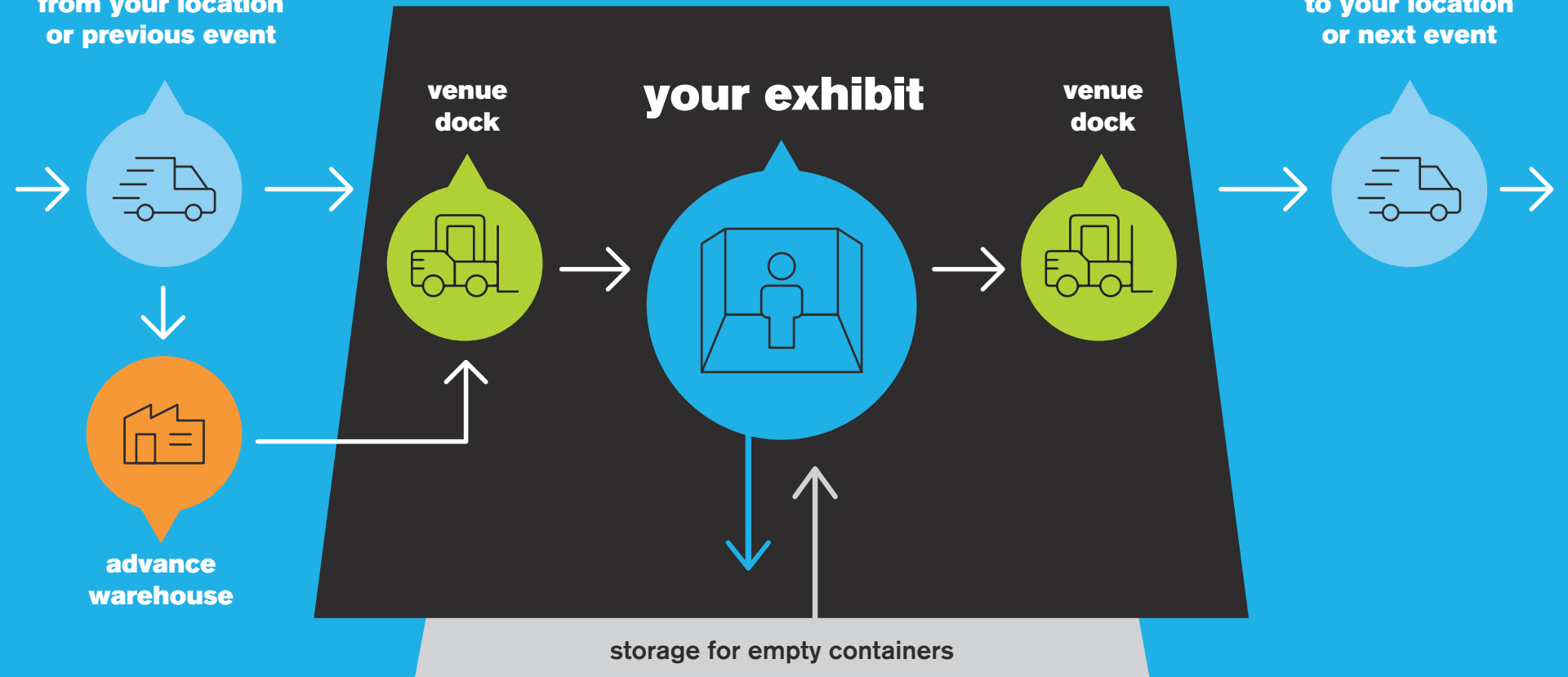

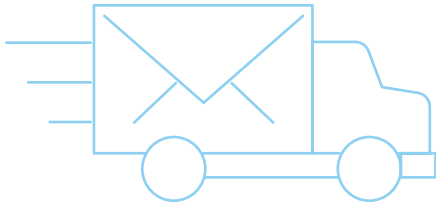

TRANSPORTATION SERVICE, FULLY LOADED.

Our convenient, affordable package puts productivity in overdrive.

Turn to Freeman for one-stop transportation services. Our all-inclusive round trip standard ground shipping and material handling package means transporting materials to any exhibit location has never been easier or more affordable. Plus, Freeman works directly with you and show site decision makers to streamline the process, so it's faster than ever to get on the road to success.

The Freeman Exhibit Transportation promise:

- ▮ ALL-INCLUSIVE PRICING WITH NO ADDITIONAL FEES FOR PICKUPS AND DELIVERIES, INCLUDING WEEKEND AND NIGHT SERVICE
- ▮ PICK-UP AND TRANSPORTATION FROM POINT OF ORIGIN TO YOUR CHOICE OF EITHER ADVANCE WAREHOUSE OR SHOW SITE
- ▮ ON-SITE TRANSPORTATION EXPERTS ARE AVAILABLE BEFORE, DURING AND AFTER THE SHOW
- ▮ RELIABLE CUSTOMER SERVICE SEVEN DAYS A WEEK, OFFERING COMPLETE SHIPMENT VISIBILITY AND EXPERT SUPERVISION
- ▮ PRE-PRINTED SHIPPING LABELS AND OUTBOUND PAPERWORK

Benefits:

- ▮ TURNKEY PRICING ENSURES PRECISE BUDGETING
- ▮ NO ADDITIONAL HANDLING, PICK-UP OR DELIVERY FEES
- ▮ NO ADDITIONAL FUEL SURCHARGES OR OVERTIME SURCHARGES
- ▮ NO CARRIER WAITING TIME FEES
- ▮ EXPERIENCED ON-SITE TRANSPORTATION REPS FROM MOVE-IN THROUGH MOVE-OUT
- ▮ LTL (LESS THAN TRUCK LOAD) SHIPPING

*Services apply to destinations anywhere in the Continental U.S.



To take advantage, call **1-800-995-3579** or email **exhibit.transportation@freeman.com** for a quote.

RESULTS, DELIVERED

With more than 90 years of experience in the events industry, no one understands exhibit transportation better than Freeman. Our transportation services are a seamless extension of the premium products that exhibitors around the world rely on time and time again.

Between our all-inclusive pricing and superior customer service, Freeman Exhibit Transportation is the most reliable, convenient and cost-effective solution available. Our team of experts has the ability to quickly respond to changes when necessary, remaining entirely responsive to all of your show requirements, whenever and wherever they arise.

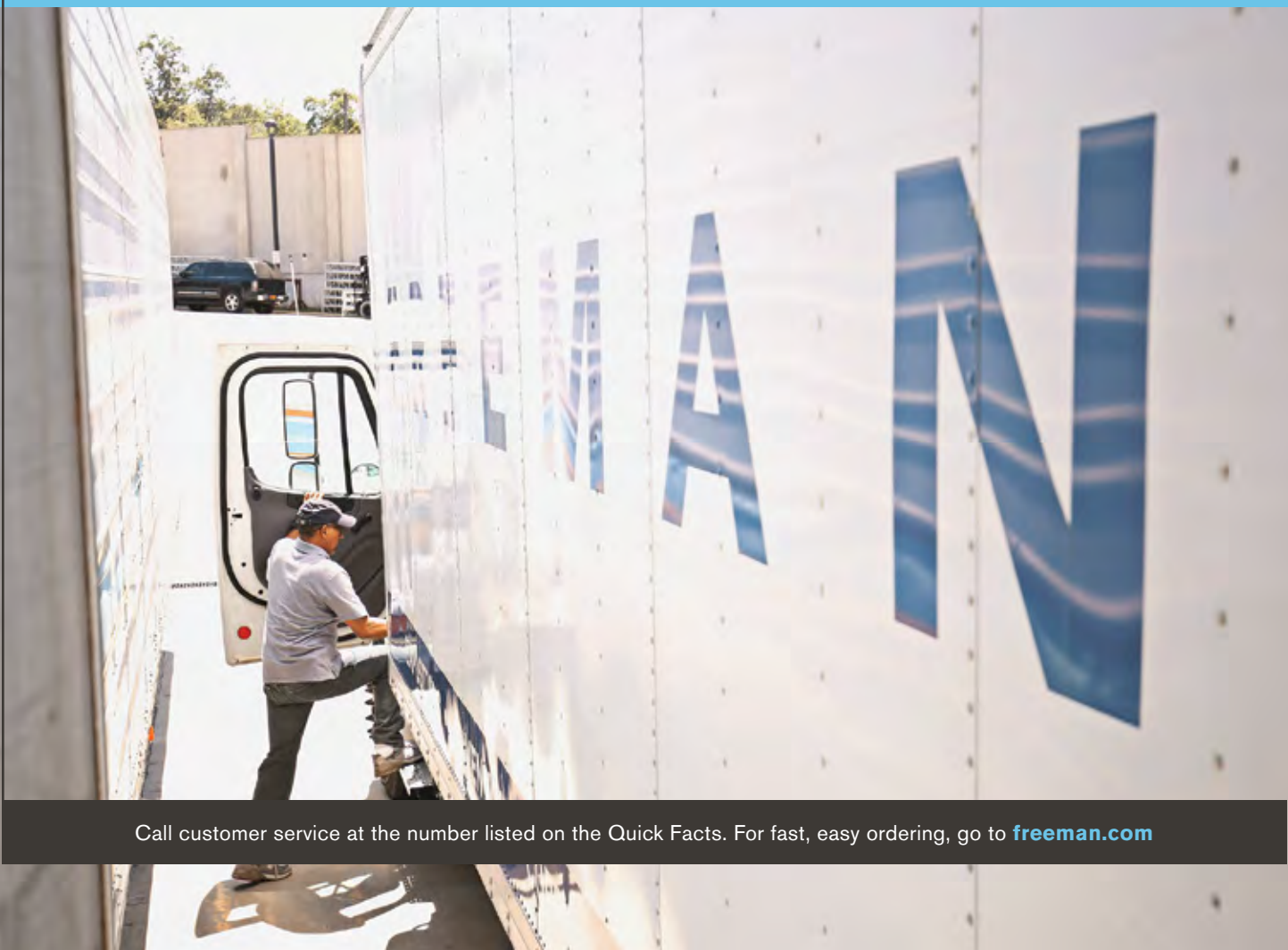

Call customer service at the number listed on the Quick Facts. For fast, easy ordering, go to freeman.com

EXHIBIT TRANSPORTATION SERVICES

Freeman Exhibit Transportation is an EPA Smartway Partner and is dedicated to reducing carbon emissions related to the transportation of goods. Renting or shipping items locally saves on carbon emissions and your shipping footprint.

Freeman Exhibit Transportation promise:

- ALL-INCLUSIVE PRICING WITH NO ADDITIONAL FEES FOR PICKUPS AND DELIVERIES, INCLUDING WEEKEND AND NIGHT SERVICE
- ONE CONVENIENT INVOICE ENCOMPASSING ALL FREEMAN SHOW SERVICES
- ON-SITE TRANSPORTATION EXPERTS ARE AVAILABLE BEFORE, DURING AND AFTER THE SHOW
- RELIABLE CUSTOMER SERVICE SEVEN DAYS A WEEK, OFFERING COMPLETE SHIPMENT VISIBILITY AND EXPERT SUPERVISION

Questions?

For more information regarding our services, rates, shipment deadlines, documentation requirements, ordering and the terms and conditions of our service offerings, please visit freeman.com

Continental U.S. Exhibitors: Contact our exhibit transportation experts at **800.995.3579** or via email at exhibit.transportation@freeman.com

International Exhibitors: Contact our exhibit transportation experts at **+1.817.607.5183** or via email at international.freight@freeman.com

DON'T FORGET ABOUT INBOUND SHIPPING! COMPLETE AND SEND THE ORDER FORM

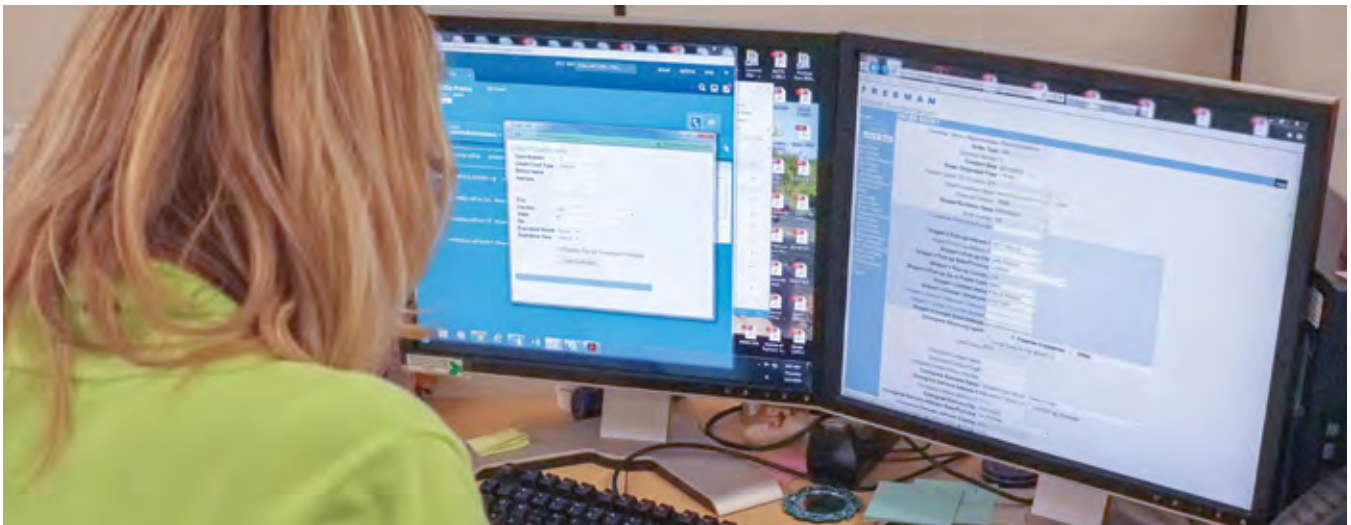

FREEMAN

(800) 995-3579 Toll Free US & Canada
(817) 607-5183 Local & International

COMPLETE THIS FORM ONLY IF YOU ARE SHIPPING YOUR EXHIBIT MATERIALS BY FREEMAN EXHIBIT TRANSPORTATION

exhibit transportation

NAME OF SHOW: **New Cardiovascular Horizons Conference / June 2 - 4, 2021**

COMPANY NAME: _____ BOOTH #: _____

CONTACT NAME : _____ PHONE #: _____

E-MAIL ADDRESS : _____

For fast, easy ordering, go to www.freeman.com/store.

EXHIBIT TRANSPORTATION

TIPS FOR EASY ORDERING

- Credit card information must be on file prior to pick up, as charges will be included on your show services invoice.
- International Exhibitors remember - Shipments originating from countries other than the US must be cleared through customs. Please call for additional information:
(800) 995-3579 Toll Free US & Canada
(817) 607-5183 Local & International

COMPLETE THE FOLLOWING ITEMS ON THIS FORM:

PICK UP INFORMATION

Requested Pick Up Date: _____

SHIPPER NAME _____

SHIPPER ADDRESS _____

(City) (State) (Zip Code)

DESTINATION

- I will be shipping to the **WAREHOUSE**

FREEMAN / Exhibiting Company Name / Booth #

New Cardiovascular Horizons Conference

C/O: FREEMAN
905 SAMS AVE
NEW ORLEANS, LA 70123

MUST BE DELIVERED BY MAY 26, 2021

- I will be shipping to **SHOW SITE**

FREEMAN / Exhibiting Company Name / Booth #

New Cardiovascular Horizons Conference

C/O: FREEMAN
ROOSEVELT HOTEL
116 UNIVERSITY PL
NEW ORLEANS, LA 701122502

CANNOT BE DELIVERED BEFORE JUNE 01, 2021

TYPE OF SERVICE

- Next Day Air: Delivery next business day by 5:00 PM
 Second Day Air: Delivery second business day by 5:00 PM
 3-5 Day Service: Delivery within 3 - 5 business days
 Declared Value \$ _____

Air Transportation charges are billed by Dimensional or Actual Weight, whichever is greater.

- Standard Ground: Dependent on distance
 Expedited Ground: Tailored to specific requirements
 Specialized: Pad wrapped, uncrated, truck load

01/21

SHIPPING INFORMATION

Items to be shipped

Number of Pieces	Est. Weight
____ Crates (wooden)	_____
____ Cartons (cardboard)	_____
____ Cases/Trunks (fiber) (color _____)	_____
____ Skids/Pallets	_____
____ Carpet (color _____)	_____
____ Other (_____)	_____
____ Total	_____

Size of largest piece: (H) _____ (W) _____ (L) _____

NOTE: Shipments will be weighed and measured prior to delivery.

OUTBOUND SHIPPING

- I would like to schedule outbound Freeman Exhibit Transportation. Please provide me with a Material Handling Agreement at show site for my shipping instructions and signature. So we may print your Outbound Material Handling Agreement and labels, please complete the following information **if different from pick up address:**

Ship to address:

Number of Labels : _____

FAX THIS COMPLETED FORM VIA:

E-mail:

exhibit.transportation@freeman.com

or

Fax: (469) 621-5810

A TRANSPORTATION SPECIALIST
WILL CALL YOU TO CONFIRM
RECEIPT OF SHIPMENT REQUEST
AND FINALIZE DETAILS.

SHOW # (505640) _____

WHAT ARE FREIGHT SERVICES?

As the official service contractor, Freeman is the exclusive provider of freight services. Material handling includes unloading your exhibit material, storing up to 30 days in advance at the warehouse address, delivering to the booth, the handling of empty containers to and from storage, and removing of material from the booth for reloading onto outbound carriers. It should not be confused with the cost to transport your exhibit material to and from the convention or event. You have two options for shipping your advance freight — either to the warehouse or directly to show site.

HOW DO I SHIP TO THE WAREHOUSE?

- We will accept freight beginning 30 days prior to show move-in.
- To check on your freight arrival, call Exhibitor Services at the location listed on the Quick Facts.
- To ensure timely arrival of your materials at show site, freight should arrive by the deadline date listed on the Quick Facts. Your freight will still be received after the deadline date, but additional charges will be incurred.
- The warehouse will receive shipments Monday through Friday, except holidays. Refer to the Quick Facts for warehouse hours. No appointment is necessary.
- The warehouse will accept crates, cartons, skids, trunks/cases and carpets/pads. Loose or pad-wrapped material must be sent directly to show site.
- All shipments must have a bill of lading or delivery slip indicating the number of pieces, type of merchandise and weight.
- Shipments received without receipts or freight bills, such as Federal Express and UPS, will be delivered to the booth without guarantee of piece count or condition.
- Certified weight tickets must accompany all shipments.
- Warehouse freight will be delivered to the booth prior to exhibitor set up.

HOW DO I SHIP TO SHOW SITE?

- Freight will be accepted only during exhibitor move-in. Please refer to the Quick Facts for the specific exhibitor move-in dates and times.
- All shipments must have a bill of lading or delivery slip indicating the number of pieces, type of merchandise and weight.
- Shipments received without receipts or freight bills, such as Federal Express and UPS, will be delivered to the booth without guarantee of piece count or condition.
- Certified weight tickets must accompany all shipments.

WHAT ABOUT PREPAID OR COLLECT SHIPPING CHARGES?

- Collect shipments will be returned to the delivery carrier.
- To ensure that your freight does not arrive collect, mark your bill of lading “prepaid.”
- “Prepaid” designates that the transportation charges will be paid by the exhibitor or a third party.

HOW SHOULD I LABEL MY FREIGHT?

- The label should contain the exhibiting company name, the booth number and the name of the event.
- The specific shipping address for either the warehouse or show site is located on the Quick Facts.

HOW DO I ESTIMATE MY MATERIAL HANDLING CHARGES?

- Charges will be based on the weight of your shipment. Each shipment received is billed individually and is subject to the applicable show weight minimum. The shipment weight will be rounded to the next 100 pounds. Each 100 pounds is considered one “cwt.” (one hundred weight). All shipments are subject to reweigh.
- On the Material Handling Order Form, select whether the freight will arrive at the warehouse or be sent directly to show site.
- Next, select the rate for the freight category that best describes your shipment. There are four categories of freight:

Crated: material that is skidded or is in any type of shipping container that can be unloaded at the dock with no additional handling required.

Special Handling: material delivered by the carrier in such a manner that it requires additional handling, such as ground unloading, stacked and constricted space unloading, designated piece unloading, loads mixed with pad-wrapped material, loads failing to maintain shipping integrity, and shipments that require additional time, equipment or labor to unload. Federal Express and UPS are included in this category due to their delivery procedures.

Uncrated: material that is shipped loose or pad-wrapped, and/or unskidded machinery without proper lifting points.

Carpet and/or Pad Only: shipments that consist of loose carpet and/or padding only require additional labor and equipment to unload.

- All inbound and outbound shipments are subject to overtime charges if the shipments are received, loaded or unloaded during the overtime hours specified on the Material Handling Order Form. This includes both warehouse and show site shipments.
- Add any late delivery or off-target charges listed on the Material Handling Order Form if the freight will be received after the deadlines listed on the Quick Facts.
- The above services, whether used completely or in part, are offered as a package and the charges will be based on the total inbound weight of the shipment.

WHAT HAPPENS TO MY EMPTY CONTAINERS DURING THE SHOW?

- Pick up “Empty Labels” at the Freeman Service Center. Once the container is completely empty, place a label on each container individually. Labeled empty containers will be picked up periodically and stored in non-accessible storage during the event.
- At the close of the show, the empty containers will be returned to the booth in random order. Depending on the size of the show, this process may take several hours.

HOW DO I PROTECT MY MATERIALS AFTER THEY ARE DELIVERED TO THE SHOW OR BEFORE THEY ARE PICKED UP AFTER THE SHOW?

- Consistent with trade show industry practices, there may be a lapse of time between the delivery of your shipment(s) to your booth and your arrival. The same is true for the outbound phase of the show — the time between your departure and the actual pick-up of your materials. During these times, your materials will be left unattended. We recommend that you arrange for a representative to stay with your materials or that you hire security services to safeguard your materials.

HOW DO I SHIP MY MATERIALS AFTER THE CLOSE OF THE SHOW?

- Each shipment must have a completed Material Handling Agreement in order to ship materials from the show. All pieces must be labeled individually.
- To save time, complete and submit the Outbound Shipping Form in advance, or you may contact the Freeman Service Center at show site for your shipping documents.
- Once we receive your outbound shipping information we will create your Material Handling Agreement and shipping labels. If the shipping information is provided in advance, the Material Handling Agreement will be delivered to your booth with your invoice. Otherwise the Material Handling Agreement and labels will be available for pick up at the Freeman Service Center.

- After materials are packed, labeled, and ready to be shipped, the completed Material Handling Agreement must be turned in at the Freeman Service Center.
- Call your designated carrier with pick-up information. Please refer to the Quick Facts for specific dates, times and address for pick up. In the event your selected carrier fails to show by the final move-out day, your shipment will either be rerouted on Freeman’s carrier choice or delivered back to the warehouse at the exhibitor’s expense.
- For your convenience, approved show carriers will be on site to book outbound transportation if you have not made arrangements in advance.

WHERE DO I GET A FORKLIFT?

- Forklift orders to install or dismantle your booth after materials are delivered may be ordered in advance or at show site. We recommend that you order in advance to avoid additional charges at show site. Refer to the Rigging Order Form for available equipment.
- Advance and show site orders for equipment and labor will be dispatched once a company representative signs the labor order at the Freeman Service Center.
- Start time is guaranteed only when equipment is requested for the start of the working day.

DO I NEED INSURANCE?

- Be sure your materials are insured from the time they leave your firm until they are returned after the show. It is suggested that exhibitors arrange all-risk coverage. This can be done by riders to your existing policies.
- All materials handled by Freeman are subject to the Terms and Conditions, which can be found in the exhibit service manual or online at www.freeman.com.

OTHER AVAILABLE FREIGHT SERVICES

(may not be available in all locations)

- Cranes
- Accessible storage at show site
- Exhibit transportation services (see enclosed brochure)
- Security storage at show site
- Short-term and long-term warehouse storage
- Local pick-up and delivery
- Priority empty return

FREEMAN

(888) 508-5054 • Fax (469) 621-5612

ExhibitorSupport@freeman.com

FREEMAN material handling

NAME OF SHOW: **New Cardiovascular Horizons Conference / June 2 - 4, 2021 HOTEL**

COMPANY NAME _____ BOOTH #: _____

CONTACT NAME: _____ PHONE #: _____

E-MAIL ADDRESS _____

For Assistance, please call 888-508-5054 to speak with one of our experts.

Let FreemanOnline® estimate your material handling charges for you. Log on to www.freeman.com/store, select your show and click on "Estimate My Material Handling Costs". From FreemanOnline® you can print extra shipping labels, get tips on how to package your freight and much more.

MATERIAL HANDLING SERVICES

- CRATED:** Material that is skidded or is in any type of shipping container that can be unloaded at the dock with no additional handling required.
- SPECIAL HANDLING:** (See definitions on back) Material delivered by a carrier in such a manner that it requires additional handling, such as ground unloading, stacked or constricted space unloading, designated piece unloading, shipment integrity, alternate delivery location, loads mixed with pad wrapped material, carpet and/or pad only shipments, no documentation and shipments that require additional time, equipment or labor to unload. **Federal Express, UPS and DHL** are included in this category due to their delivery procedures.
- UNCRATED:** Material that is shipped loose or pad-wrapped, and/or unskidded machinery without proper lifting points.
- CARPET AND/OR PAD ONLY:** Shipments that consist of loose carpet and/or padding only require additional labor and equipment to unload
- STRAIGHT TIME:** 8:00 A.M. to 5:00 P.M. Monday through Friday
- OVERTIME:** 5:00 P.M. to 8:00 A.M. Monday through Friday, all day Saturday, Sunday, and Holidays (Overtime will be applied to all freight received at the warehouse and/or show site that must be moved into or out of booth during above listed times.)

Description	Price Per CWT	200 lb. Minimum
-------------	---------------	-----------------

RATE CLASSIFICATIONS:

Warehouse Shipment (200 lb. minimum)

Crated or Skidded Shipment.....	\$ 92.75	185.50
Special Handling Shipment.....	\$120.75	241.50
Carpet and/or Pad Only Shipment.....	\$139.25	278.50

Show Site Shipment (200 lb. minimum)

Crated or Skidded Shipment.....	\$ 96.00	192.00
Special Handling Shipment.....	\$125.00	250.00
Uncrated or Pad Wrapped Shipment.....	\$144.00	288.00
Carpet and/or Pad Only Shipment.....	\$144.00	288.00

Small Package - Maximum weight is 30 lbs per shipment* \$ 40.00

*A small package shipment is a shipment totaling any number of pieces with a combined weight not to exceed 30 lbs that is received on the same day, from the same shipper and delivered by the same carrier.

ADDITIONAL SURCHARGES:

Shipment Delivered after Deadline Date (in addition to above rates)

Warehouse Shipment after May 26, 2021.....	\$ 23.25	46.50
Show Site Shipment after Show Opening.....	\$ 24.00	48.00

Overtime Charge - Inbound (in addition to above rates)

Crated or Skidded Shipment.....	\$ 24.00	48.00
Special Handling Shipment.....	\$ 31.25	62.50
Uncrated or Pad Wrapped Shipment.....	\$ 36.00	72.00
Carpet and/or Pad Only Shipment.....	\$ 36.00	72.00

Overtime Charge - Outbound (in addition to above rates)

Crated or Skidded Shipment.....	\$ 24.00	48.00
Special Handling Shipment.....	\$ 31.25	62.50
Uncrated or Pad Wrapped Shipment.....	\$ 36.00	72.00
Carpet and/or Pad Only Shipment.....	\$ 36.00	72.00

Description	Weight	CWT	Price per CWT	Estimated Total Cost (200 lb. Min.)
	÷ 100 =			
Surcharges	÷ 100 =			
			2% Tax	
			Total	

SPECIAL HANDLING DEFINITIONS

For frequently asked questions and material handling estimator tools, go to www.freeman.com/store

Special handling applies to shipments that are loaded by cubic space and/or packed in such a manner as to require additional labor/handling, such as ground unloading, constricted space unloading, designated piece unloading, carpet/pad only shipments or stacked shipments. Also included are shipment integrity, alternate delivery locations, mixed shipments, and shipments without individual bills of lading. Shipments loaded in this manner require additional time, labor, or equipment, to unload, sort and deliver.

What is Ground Loading/Unloading?

Vehicles that are not dock height, preventing the use of loading docks, such as U-hauls, flat bed trailers, double drop trailers, company vehicles with trailers that are not dock level, etc.

What is Constricted Space Loading/Unloading?

Trailer loaded “high and tight” shipments that are not easily accessible. Freight is loaded to full capacity of trailer – top to bottom, side to side. One example of this is freight that is loaded down one side of a trailer that must be bypassed to reach targeted freight.

What is Designated Piece Loading/Unloading?

Drivers that require the loading crew to bring multiple pieces of the freight to the rear of the trailer to select the next piece, having to remove freight from the trailer then reload to fit or the trailer must be loaded in a sequence to ensure all items fit.

What are Stacked Shipments?

Shipments loaded in such a manner requiring multiple items to be removed to ground level for delivery to booth. Stacked or “cubed out” shipments, loose items placed on top of crates and/or pallets constitute special handling.

What is Shipment Integrity?

Shipment integrity involves shipments on a carrier that are intermingled, or delivered in such a manner that additional labor is needed to sort through and separate the various shipments on a truck for delivery to our customers.

What is Alternate Delivery Location?

Alternative delivery location refers to shipments that are delivered by a carrier that requires us to deliver some shipments to different levels in the same building, or to other buildings in the same facility.

What are Mixed Shipments?

Mixed shipments are defined as shipments of mixed crated and uncrated goods, where the percentage of uncrated is minimal and does not warrant the full uncrated rate for the shipment, but does require special handling. Freeman defines special handling for mixed loads as having less than 50% of the volume as uncrated.

What does it mean if I have “No Documentation”?

Shipments arrive from a small package carrier (including, among others, Federal Express, UPS & DHL) without an individual Bill of Lading, requiring additional time, labor and equipment to process.

What is the difference between Crated and Uncrated Shipments?

Crated shipments are those that are packed in any type of shipping container that can be unloaded at the dock with no additional handling required. Such containers include crates, fiber cases, cartons, and properly packed skids. An uncrated shipment is material that is shipped loose or pad-wrapped, and/or unskidded without proper lifting points.

What about carpet only shipments?

Shipments that consist of carpet and/or carpet padding only require additional labor and equipment to unload.

FREEMAN

(888) 508-5054 Fax: (469) 621-5612
ExhibitorSupport@freeman.com

NAME OF SHOW: **New Cardiovascular Horizons Conference / June 2 - 4, 2021**

COMPANY NAME: _____ BOOTH #: _____

CONTACT NAME : _____ PHONE #: _____

E-MAIL ADDRESS : _____

For fast, easy ordering, go to www.freeman.com/store.

EVERY OUTBOUND SHIPMENT WILL REQUIRE A MATERIAL HANDLING AGREEMENT AND SHIPPING LABELS. WE WOULD BE HAPPY TO PREPARE THESE FOR YOU AND DELIVER THEM TO YOUR BOOTH PRIOR TO SHOW CLOSE. TO TAKE ADVANTAGE OF THIS SERVICE, PLEASE COMPLETE AND RETURN THIS FORM TO THE FREEMAN SERVICE CENTER.

SHIPPING INFORMATION

SHIP TO: COMPANY NAME: _____

DELIVERY ADDRESS: _____

CITY: _____ STATE/ PROVINCE: _____ ZIP/ POSTAL CODE: _____

PHONE#: _____ ATTN: _____

SPECIAL INSTRUCTIONS: _____

BILL TO: Same as Ship to:

COMPANY NAME: _____

DELIVERY ADDRESS: _____

CITY: _____ STATE/ PROVINCE: _____ ZIP/ POSTAL CODE: _____

METHOD OF SHIPMENT

Select a Carrier:

- Freeman Exhibit Transportation Other Carrier

No need to schedule your outbound shipment.
Charges will appear on your Freeman invoice.

Carrier Name: _____
Carrier Phone: _____

Freeman will make arrangements for all Freeman Exhibit Transportation shipments.
Arrangements for pick-up by other carriers is the responsibility of the exhibitor.

Select a Level of Service:

- 1 Day: Delivery next business day Standard Ground
 2 Day: Delivery by 5:00 PM second business day Specialized: Pad wrapped, uncrated, or truckload
 Deferred: Delivery within 3-5 business days

Select Shipment Options (if applicable)

- Have loading dock Lift gate required
 Inside delivery Air ride required
 Pad wrap required Residential
 Do not stack

Select Desired Number of Labels: _____

Once your shipment is packed and ready to be picked up from your booth, please return completed the Material Handling Agreement to the Freeman Service Center. Shipments without a Material Handling Agreement turned in will be returned to our warehouse at exhibitor's expense.

F R E E M A N

R U S H

DO NOT DELAY

F R E E M A N

R U S H

DO NOT DELAY

RECEIVING DATE BEGINS: MAY 17, 2021

RECEIVING DATE BEGINS: MAY 17, 2021

DEADLINE DATE IS: MAY 26, 2021

DEADLINE DATE IS: MAY 26, 2021

TO: _____

EXHIBITOR NAME

TO: _____

EXHIBITOR NAME

**C/O: FREEMAN
905 SAMS AVE**

**C/O: FREEMAN
905 SAMS AVE**

NEW ORLEANS, LA 70123

NEW ORLEANS, LA 70123

WAREHOUSE

WAREHOUSE

(505640)

(505640)

New Cardiovascular Horizons

New Cardiovascular Horizons

**EVENT: _____
*Conference***

**EVENT: _____
*Conference***

BOOTH NO: _____ NO. _____ OF _____ PCS

BOOTH NO: _____ NO. _____ OF _____ PCS

THE ABOVE LABELS ARE PROVIDED FOR YOUR CONVENIENCE.
PLACE ONE ON EACH PIECE SHIPPED TO ENSURE PROPER DELIVERY.
IF MORE LABELS ARE NEEDED, COPIES ARE ACCEPTABLE.

F R E E M A N

F R E E M A N

R U S H

R U S H

DO NOT DELAY

DO NOT DELAY

CANNOT DELIVER BEFORE JUNE 01, 2021

CANNOT DELIVER BEFORE JUNE 01, 2021

TO:

EXHIBITOR NAME

TO:

EXHIBITOR NAME

C/O: FREEMAN

**ROOSEVELT HOTEL
116 UNIVERSITY PL**

NEW ORLEANS, LA 701122502

SHOW SITE

(505640)

***New Cardiovascular Horizons
Conference***

EVENT: _____

C/O: FREEMAN

**ROOSEVELT HOTEL
116 UNIVERSITY PL**

NEW ORLEANS, LA 701122502

SHOW SITE

(505640)

***New Cardiovascular Horizons
Conference***

EVENT: _____

BOOTH NO: _____ NO. _____ OF _____ PCS

BOOTH NO: _____ NO. _____ OF _____ PCS

THE ABOVE LABELS ARE PROVIDED FOR YOUR CONVENIENCE.
PLACE ONE ON EACH PIECE SHIPPED TO ENSURE PROPER DELIVERY.
IF MORE LABELS ARE NEEDED, COPIES ARE ACCEPTABLE.

FREEMAN®

furnishings 2020



Nationwide Service

Visit us at freeman.com or call 1.888.508.5054 for customer service, 7am-7pm CT Monday through Friday and 8am-5pm CT Saturday.

FREEMAN® Trade Show Furnishings are proud to offer this collection of the highest quality, design-oriented furnishings. Our nationwide distribution and professional staff is dedicated to the success of your exhibit. Make FREEMAN® Trade Show Furnishings your furniture solution.



EMPOWERING YOUR BUSINESS FROM THE GROUND UP

Meaningful engagement doesn't have to be complicated. You just need the right elements. Whether you're a global brand testing a new product, a startup seeking exposure, or an organization needing flexibility, the furnishings to create a dynamic brand experience start here. To learn more about our exhibit solutions, go to freeman.com/exhibit-design

**It's not about building a booth.
It's about designing a**

beacon

Fairfax Sofa & La Brea Chair
10'x10' Booth



10'x10' Munich Sectional Booth



10'x20' Malba Café & Bench Theater Booth

Top 10 Booth Design Tips

Attract, Engage and Inspire.

10.

Provide a Pop!
Colorful furnishings attract attention and help reinforce brand themes.



1.

Spin Around.
Swivel chairs in small spaces maximize functionality and allow you to engage with those all around!

2.

Get Connected.
Communal tables help facilitate networking opportunities and build connections.



9.

Charge it!
Powered tables and seating encourages clients to linger in the booth and recharge.



3.

Create Comforts.
Design a comfortable "living room" space with soft lounge seating to relax clients and encourage conversation.

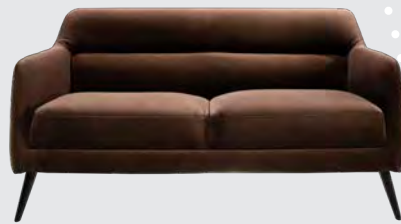

8.

Gather Round!
Ottomans styled around a side table create an informal campfire setting for small group discussions.



4.

Keep it Green.
Don't forget the greenery to warm up your booth environment by bringing nature indoors.



7.

Stay Social.
Stylize furnishings to create shareable moments worthy of Instagram.



6.

Level the field!
Low and casual seating makes clients more comfortable and open to learning.



5.

Demo Down.
Square or circular ottomans are a great way to design small theaters for quick demonstrations.

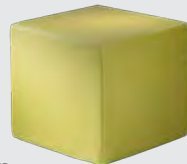

Roma Powered Seating and Rustique Table Booth
10'x20'



Denotes AC and USB charging outlets

Keep clients charged with powered seating and add a wireless charging table for attendees without charging cords.

Malba Conference and Beverly Demonstration Booth
10'x20'



Create a comfortable "living room" space with soft lounge seating to relax clients and facilitate conversation.

Munich Sectional Booth
10'x10'



Denotes AC and USB charging outlets

Design multifunctional booths with areas for demonstrations and a place for conferencing.

Power Up In Style.

Denotes Powered Products



HEDGE

85035
4' Boxwood Hedge
46"L 9"D 47"H



ROMA

81021 Chair, Powered
(white vinyl) 37"L 31"D 33"H



ROMA

83017 Sofa, Powered
(white vinyl) 78"L 31"D 33"H



POWERED
DETAIL

WIRELESS
CHARGING TABLE,
POWERED
820710
(white, AC plug-in)
20"L 20"D 18"H



POWERED
DETAIL

Powered Seating

Empower attendees at your next show with functional charging furniture and make searching for wall outlets history. From soft seating and tables to pedestals and lamps, our complete charging collection lets you Power Up the Possibilities.

Powered Seating



A.



POWERED
DETAIL



B.



C.



A) 810120
Naples Chair, Powered
(black vinyl)
36"L 30"D 33.25"H

B) 830121
Naples Sofa, Powered
(black vinyl)
87"L 30"D 33.25"H

C) 830122
Naples Loveseat,
Powered
(black vinyl)
62"L 30"D 33.25"H

Powered Tables



C.



POWERED
DETAIL



A.

Ventura
POWERED
TABLES



D.



B.



Ventura Powered
Bar Tables
72.25"L 26.25"D 42"H
(silver frame)
A) 820955 (white top)
B) 820950 (black top)

Ventura Powered
Café Tables
72.25"L 26.25"D 30"H
(silver frame)
C) 820964 (black top)
D) 820965 (white top)



F.



E.



POWERED
DETAIL



Sydney Powered
Cocktail Tables
48"L 26"D 18"H
(brushed steel)
E) 82073 (white)
F) 82076 (black)

Please Note: Client is responsible for providing labor and an electrical power source to the furniture. One 110V power source is required for each charging panel. Two charging units can be daisy chained together. 10A max per charging panel.

Powered Banquettes.

Denotes Powered Products 

Modular System

Create round banquettes or custom serpentine seating. The Power Banquette system has three AC and two USB plugs built into the center cone so your client will never be left powerless. Center power cone may also be rented as a freestanding charging station.



Detail of Electrical Charging Outlet

 **Full Banquette**
w/ Electrical Charging Outlet
(white vinyl)
72" RND 51"H



 **8506 Center Cone**
w/ Electrical Charging Outlet
(white vinyl)
38" RND 51"H

8507 Quarter Curve Ottoman
(white vinyl)
53"L 22"D 18"H

Ottoman Ring
(4 curved ottoman seats)
(white vinyl)
72" RND 18"H

815119 Half Bench Ottoman
(white vinyl)
39"L 22"D 18"H

Powered Pedestals

Denotes AC and USB charging outlets 



A. | B. 

C. | D. 

E. 

(The flip top electrical units rotate 180 degrees, allowing devices to be charged from inside the locked cabinet or on the surface.)

(Mobile devices must be compatible with Qi wireless charging pad.)

Powered Locking Pedestal
(white)
A) 85061 24"L 24"D 36"H
B) 85063 24"L 24"D 42"H
(black)
C) 85060 24"L 24"D 36"H
D) 85062 24"L 24"D 42"H

Wireless Charging Table, Powered
E) 820710
(white, AC plug-in)
20"L 20"D 18"H

Please Note: Customer is responsible for providing labor and an electrical power source to the furniture. One 110V power source is required for each charging panel. Two charging units can be daisy chained together. 10A max per charging panel.

Powered Tech Desk



A. 

B. 

C.

A) 84083 Tech Desk,
Powered w/ 3 Drawer File
Cabinet
(black metal, laminate)
60"L 30"D 30"H

B) 84084 Tech Desk,
Powered
(black metal, laminate)
60"L 30"D 30"H

C) 84080 3 Drawer File
Cabinet on Castors
(black metal, laminate)
16"L 20"D 28"H

Soft Seating

Create Engaging Booth Environments

VALENCIA

810180 Chair
(spice orange velvet)
28"L 30.5"D 31"H
83045 Sofa
(coffee brown velvet)
63"L 30.5"D 31"H

HEDGE

85035
4' Boxwood Hedge
46"L 9"D 47"H

MARCHE

81540 Swivel Ottoman
(Forest Green Vinyl)
17"RND 18"H



Valencia Sofa & Chair 10'x10' Booth

HEDGE

85035
4' Boxwood Hedge
46"L 9"D 47"H

PALM BEACH

83040 Sofa
(white vinyl, brushed metal)
69"L 29"D 33"H

SWANSON

810875 Swivel Chair
(white vinyl)
28"L 25"D 30"H



Palm Beach Sofa & Swanson Chairs 10'x10' Booth

Soft Seating Collections



VALENCIA

A) 810180 Chair
(spice orange velvet)
28"L 30.5"D 31"H
B) 83045 Sofa
(coffee brown velvet)
63"L 30.5"D 31"H



BAJA

A) 81050 Chair
(white vinyl)
36"L 30.5"D 28"H

B) 83019 Sofa
(white vinyl)
86"L 28"D 30"H



C) 83020 Loveseat
(white vinyl)
61"L 30.5"D 28"H



TANGIERS

A) 830118 Sofa
(beige textured)
78"L 37"D 36"H

B) 810118 Chair
(beige textured)
34"L 37"D 36"H

C) 830220 Loveseat
(beige textured)
57.5"L 37"D 37"H

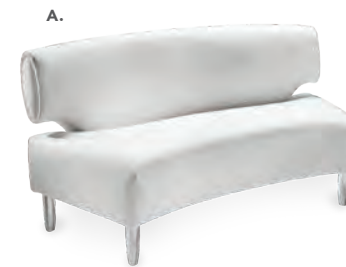

PALM BEACH

A) 83040 Sofa
(white vinyl, brushed metal)
69"L 29"D 33"H

Munich Collection

Modular Seating to Design Custom Exhibits

Denotes Powered Products



MUNICH

830201 Sectional 3pc.
(gray fabric)
93.5"L 27"D 28.5"H



HEDGE

85035
4' Boxwood Hedge
46"L 9"D 47"H



WIRELESS CHARGING TABLE, POWERED

820710
(white, AC plug-in)
20"L 20"D 18"H



830200 Munich Armless Loveseat
(gray fabric)
45"L 27"D 28.5"H



810150 Munich Corner Chair
(gray fabric)
26"L 27"D 28.5"H



810151 Munich Armless Chair
(gray fabric)
22.5"L 27"D 28.5"H

Soft Seating Collections

Available in Power



A.

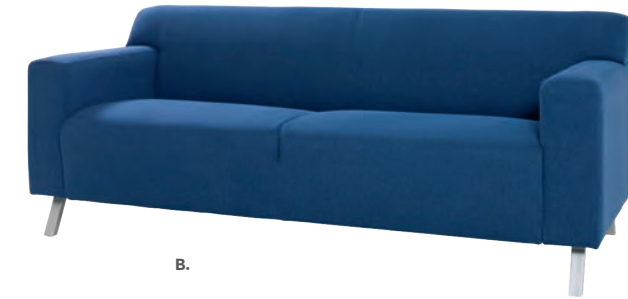

B.

ALLEGRO

A) 81019 Chair
(blue fabric)
36"L 34.5"D 30"H
B) 83015 Sofa
(blue fabric)
73"L 34.5"D 30"H



A.



B.



C.

KEY LARGO

A) 810950 Chair
(black fabric)
35"L 35"D 34"H
B) 830950 Loveseat
(black fabric)
57"L 35"D 34"H
C) 830951 Sofa
(black fabric)
79"L 35"D 34"H



A.



B.

FAIRFAX

A) 830949 Sofa
(white vinyl, brushed metal)
62"L 26"D 30"H
B) 810949 Chair
(white vinyl, brushed metal)
27"L 26"D 30"H



A.



B.



C.

NAPLES

A) 810119 Chair
(black vinyl)
36"L 30"D 33.25"H
810120 (Powered)
B) 830119 Sofa
(black vinyl)
87"L 30"D 33.25"H
830121 (Powered)
C) 830120 Loveseat
(black vinyl)
62"L 30"D 33.25"H
830122 (Powered)

Accent Chairs



A.



B.



C.



D.

- A) 810874 La Brea Chair (charcoal gray, fabric) 35"L 27"D 40"H
- B) 810145 Wentworth Chair (brown vinyl) 32.1"L 26"D 31.5"H
- C) 8103 Key West Chair (black) 31"L 31"D 31"H
- D) 810875 Swanson Swivel Chair (white vinyl) 28"L 25"D 30"H

Accent Chair Styles



A.



B.



C.



D.

**A) 810816
Madrid Chair**
(white vinyl)
30"L 30"D 31"H

**B) 810949
Fairfax Chair**
(white vinyl, brushed metal)
27"L 26"D 30"H

**C) 810151
Munich Armless Chair**
(gray fabric)
22.5"L 27"D 28.5"H

**D) 810947
Pro Executive Guest Chair**
(black vinyl)
24"L 22"D 36"H

Meeting & Stage Chairs



A.



B.



C.



D.



E.



F.

Marina Chair
17.5"L 19.5"D 35"H
A) 810164 (white vinyl)
B) 810160 (black vinyl)
C) 810161 (brown fabric)

Meeting Chair
25.5"L 23.5"D 34"H
D) 810835 (espresso vinyl)
E) 810836 (taupe fabric)
F) 810948 (white vinyl)

Group Seating

ZENITH

A) 810851 Chair
(white, chrome)
18.25"L 22"D 32"H

B) 820241
Madison Hydraulic
Café Table
(chrome base, gray
acajou top)
30" RND 29"H



LAGUNA

C) 810861 Chair
(maple, chrome)
18"L 19"D 34"H

D) 8201223
Round Café Table
(white laminate top,
chrome hydraulic base)
30" RND 29"H



MALBA

20"L 20"D 32"H

A) 810131 Chair (gray)
B) 810130 Chair (green)



MARINA

17.5"L 19.5"D 35"H

A) 810164 (white vinyl)
B) 810160 (black vinyl)
C) 810161 (brown fabric)
D) 810162 (ocean blue fabric)
E) 810163 (red fabric)



Styles & Shapes



A) 810810
Berlin Chair
(black, white)
18"L 22"D 32"H

B) 810846
Christopher Chair
(white vinyl, chrome)
17"L 19"D 35"H

C) 810841
Rustique Chair w/arms
(gunmetal)
20"L 18"D 31"H

D) 81093
Lucent Chair
(frosted, acrylic)
19.5"L 19.75"D 32.5"H

E) 71089
Diamond Side Chair
(black)
21"W X 23"L X 32"H

F) 71090
Diamond Arm Chair
(black)
20"W X 21"L X 33"H

G) 810837
Razor Armless Chair
(white)
15.38"L 15.5"D 30.5"H

H) 81083
Blade Chair
(sky blue)
20.5"L 19"D 30.5"H

I) 81082
Blade Chair
(red)
20.5"L 19"D 30.5"H

Mix & Match

Create the ultimate seating configuration. Choose from a variety of shapes and sizes to design the perfect look.

J) 210108 LIMERICK® Chair BY HERMAN MILLER™
(gray) 18"W X 17.75"L X 33"H



Ottomans

Vibe Cube

18"L 18"D 18"H

- A) 81535 (citrus green vinyl)
- B) 81537 (spice orange vinyl)
- C) 81538 (desert rose vinyl)
- D) 81536 (taupe vinyl)
- E) 81531 (white vinyl)
- F) 81530 (black vinyl)
- G) 81532 (steel blue vinyl)
- H) 81534 (purple vinyl)
- I) 81533 (silver vinyl)
- J) 81519 (red vinyl)
- K) 81517 (yellow vinyl)
- L) 81518 (blue vinyl)
- M) 81525 (orange vinyl)

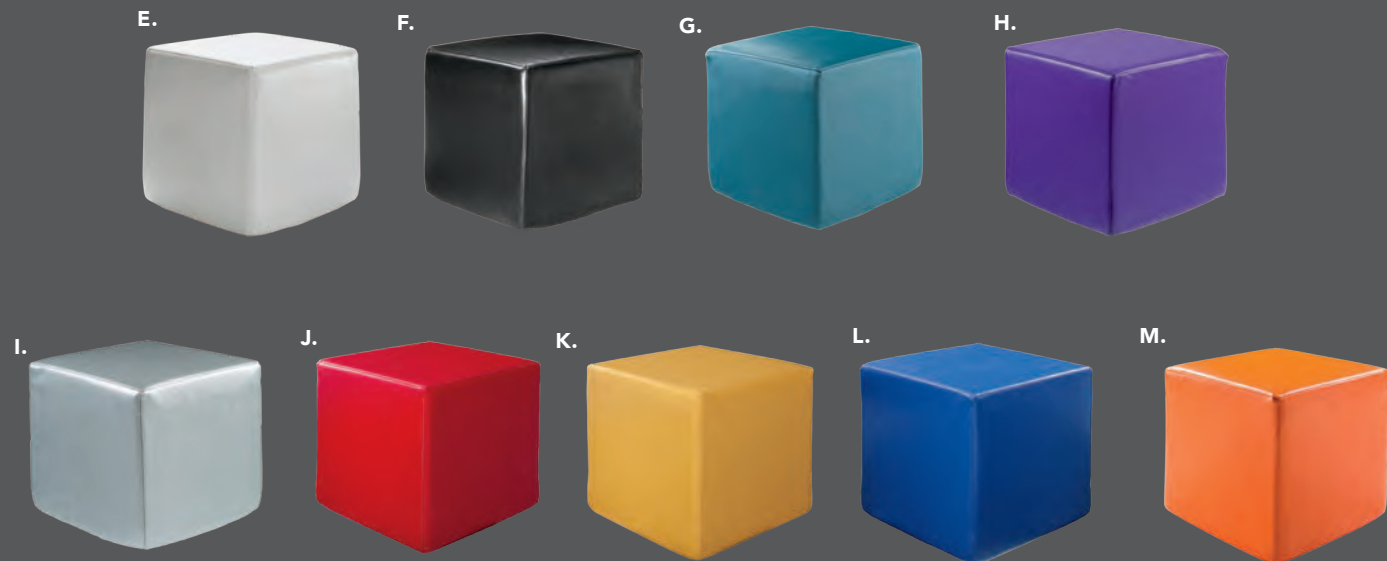
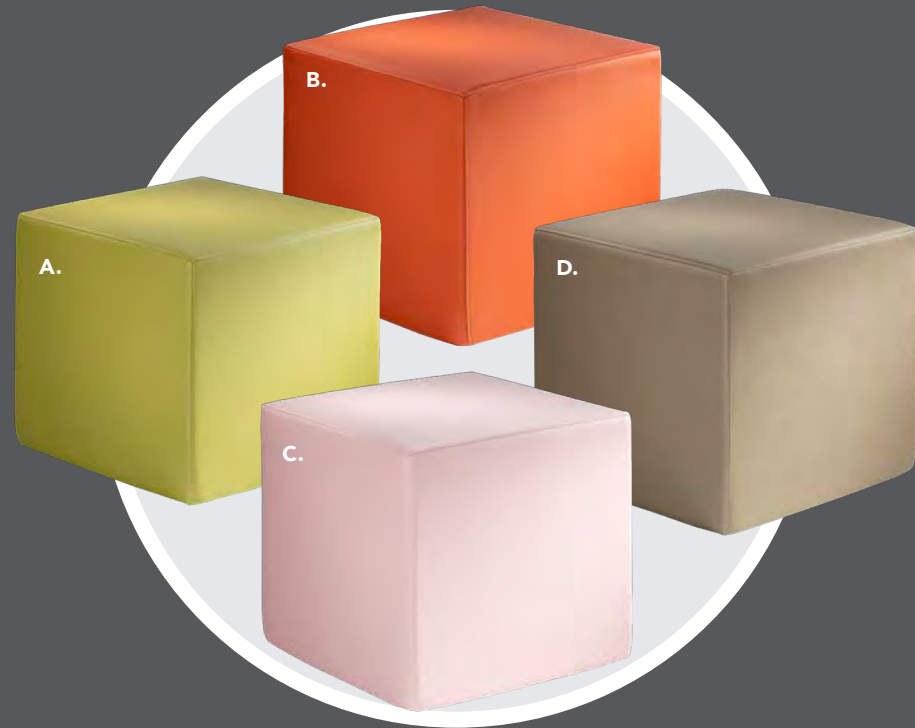

Styles & Shapes



- Beverly Bench**
60"L 20"D 18"H
- A) 81556 (white vinyl)
- B) 81550 (black vinyl)
- C) 81552 (gray fabric)
- D) 81555 (red fabric)
- E) 81554 (ocean blue fabric)
- F) 81553 (linen fabric)
- G) 81551 (brown fabric)

- H) 815119 Half Bench**
39"L 22"D 18"H

- ENDLESS Square**
34"L 34"D 15"H
- I) 815123 (black)
- J) 815122 (white)
- ENDLESS Curved**
60.5"L 37.5"D 15"H
- K) 815952 (black)
- L) 815953 (white)

- M) 8507 Quarter Curve**
(white vinyl)
53"L 22"D 18"H
- Ring** (4 ottoman seats)
(white vinyl)
72" RND 18"H

- N) 81526 Edge LED Cube**
(white plastic)
19"L 19"D 19"H
AC power only

- O) 82074 Regis Bench**
(brushed metal)
47"L 15.5"D 16"H

Marche Swivel



- Marche Swivel Ottomans**
17" RND 18"H
- A) 815150 (white vinyl)
- B) 815154 (red fabric)
- C) 815158 (pear yellow fabric)
- D) 815156 (plum fabric)
- E) 815159 (blue fabric)
- F) 815151 (gray fabric)
- G) 815155 (rose quartz fabric)
- H) 815152 (linen fabric)
- I) 815153 (raspberry fabric)
- J) 815157 (meadow green fabric)
- K) 815160 (orange fabric)
- L) 81543 (black vinyl)
- M) 81540 (forest green vinyl)
- N) 81541 (teal velvet)
- O) 81542 (distressed brown vinyl)

Accent Tables

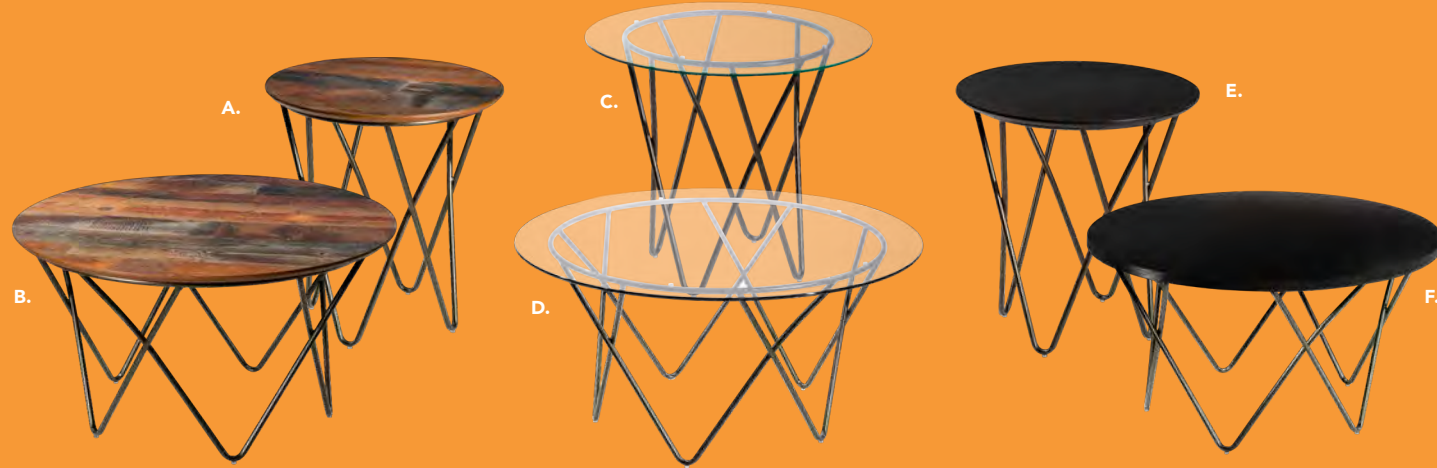

MESA

- A) 820135 End Table
20.5"RND 21.25"H (wood top, bronze)
- B) 820132 Cocktail Table
32.25"RND 17.25"H (wood top, bronze)
- C) 820134 End Table
24"RND 21.25"H (glass top, bronze)
- D) 820131 Cocktail Table
36"RND 17.25"H (glass top, bronze)
- E) 820133 End Table
20.5"RND 21.25"H (black top, bronze)
- F) 820130 Cocktail Table
32.25"RND 17.25"H (black top, bronze)

ALONDRA

- Cocktail Table
47"L 24"D 16"H
- A) 820250 (glass, chrome)
- B) 820251 (wood, chrome)
- End Table
20"L 20"D 20"H
- C) 820252 (glass, chrome)
- D) 820253 (wood, chrome)



GEO

- Cocktail Table
50"L 22"D 16"H
- A) 82034 (glass, chrome)
- B) 82027 (wood, black)
- End Table
26"L 26"D 20"H
- C) 82035 (glass, chrome)
- D) 82028 (wood, black)



Styles & Shapes

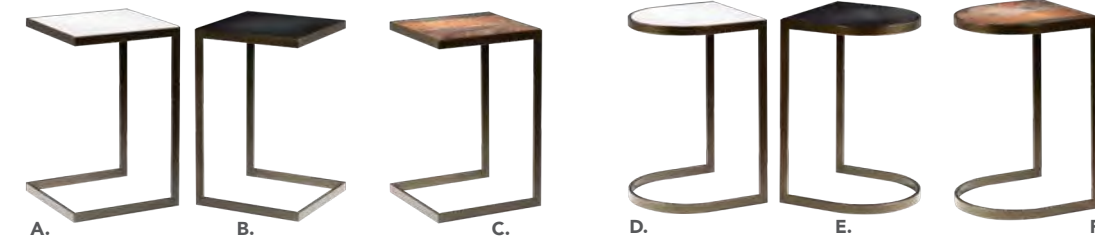

Available in Power

- Taos Side Tables**
15.75"L 15.75"D 24"H
- A) 820322
(white top, bronze)
- B) 820320
(black top, bronze)
- C) 820321
(wood top, bronze)

- Sedona Side Tables**
15.75"L 15.75"D 24"H
- D) 820312
(white top, bronze)
- E) 820310
(black top, bronze)
- F) 820311
(wood top, bronze)

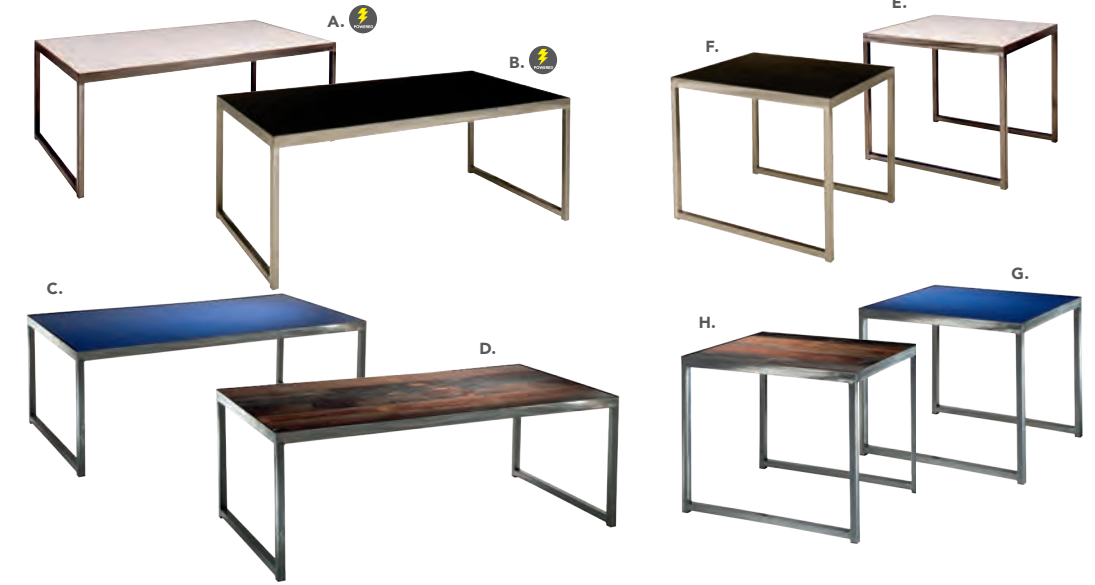

- Sydney Cocktail Tables**
(brushed steel)
48"L 26"D 18"H
- A) 82053 (white)
- 82073 (powered)
- B) 82052 (black)
- 82076 (powered)
- C) 82077 (blue)
- D) 82078 (wood)

- Sydney End Tables**
27"L 23"D 22"H
- E) 82055 (white)
- F) 82054 (black)
- G) 82079 (blue)
- H) 82080 (wood)

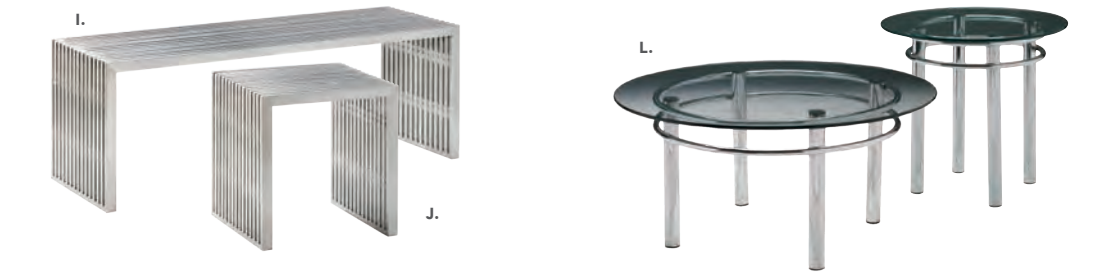

- Regis Tables**
(brushed metal)
- I) 82074 Bench Table
47"L 15.5"D 16"H
- J) 82075 End Table
16"L 15.5"D 16.5"H

- Silverado Tables**
(glass, chrome)
- K) 82015 End Table
24" RND 22"H
- L) 82014 Cocktail Table
36" RND 17"H



- Edge LED Cube Table**
M) 82057
(plexi top, white plastic)
20"L 20"D 20"H
AC power only

- Wireless Charging Table, Powered**
N) 820710
(white, AC plug-in)
20"L 20"D 18"H

- Aura Round Table**
O) 820844
(white metal)
15" Round 22"H

Café Tables



A) 820940 Blue Hydraulic Café Table
(chrome base, blue top) 30" RND 29"H
B) 810131 Malba Chair
(gray) 20"L 20"D 32"H



A) 820241 Madison Hydraulic Café Table
(chrome base, gray acajou top) 30" RND 29"H
B) 810130 Malba Chair
(green) 20"L 20"D 32"H

85030 7' Boxwood Hedge
36.5"L 12"D 84"H



30" Round Café Table
A) 820941 Standard Black Base (blue top) 30" RND 29"H
B) 81093 Lucent Chair (frosted, acrylic) 19.5"L 19.75"D 32.5"H



A) 8201233 Hydraulic Cafe Table
(orange top, chrome) 30" RND 29"H
B) 810861 Laguna Chair
(maple, chrome) 18"L 19"D 34"H

Customize and Create

Choose your base, black or chrome, then pick a color that suits your design.

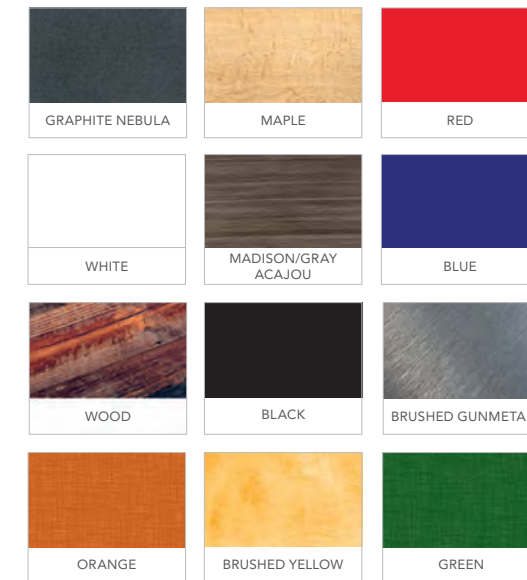

Café Tables Standard Black Base 30" RND 29"H

- A) 8201220** (white)
also available
- 820265** (Madison/gray acajou)
- 820941** (blue)
- 820943** (wood)
- 8201236** (black)
- 8201235** (brushed gunmetal)
- 8201239** (brushed yellow)
- 8201237** (green)
- 8201238** (orange)

- 36" RND 29"H
- 8201243** (black)

Café Tables Hydraulic Chrome Base 30" RND 29"H

- B) 820923** (graphite nebula)
also available
- 8201208** (maple)
- 820921** (red)
- 820940** (blue)
- 820942** (wood)
- 8201223** (white)
- 8201231** (black)
- 8201230** (brushed gunmetal)
- 8201234** (brushed yellow)
- 8201232** (green)
- 8201233** (orange)

- 36" RND 29"H
- 820126** (white)
- 8201209** (graphite nebula)
- 8201206** (maple)
- 8201242** (black)

Mix & Match

Create your look. Choose from a wide variety of tables and seating options.



C) 72063 Chelsea Butcher Block-Top Café Table
(oak) 30" RND 30"H
also available
72064 36" RND 30"H

D) 810164 Marina Chair
(white vinyl) 17.5"L 19.5"D 35"H

E) 72069 Soho Black-Top Café Table
(black) 24" RND 30"H
also available
72067 36" RND 30"H | **72066** 18" RND 18"H

F) 81082 Blade Chair
(red) 20.5"L 19"D 30.5"H



Bar Tables

A) 8201222 30" Round Bar Table
(white top, chrome hydraulic base) 30" RND 45"H
B) 810952 Apex Barstool
(blue ultra suede) 21"L 21"D 33"H



C) 8201226 Rustique Square Metal Bar Table
(gunmetal) 23.75"L 23.75"D 41.25"H
D) 810839 Rustique Barstool
(gunmetal) 13"L 13"D 30"H



E) 820930 30" Round Bar Table
(blue top, chrome hydraulic base) 30" RND 45"H
F) 810860 Laguna Barstool
(maple, chrome) 18"L 20"D 47"H



G) 820240 30" Round Bar Table w/ Hydraulic Chrome Base
(Madison/gray acajou) 30" RND 45"H
H) 810850 Zenith Barstool (white, chrome) 19"L 20"D 44"H



Customize and Create

Choose your base, black or chrome, then pick a color that suits your design.

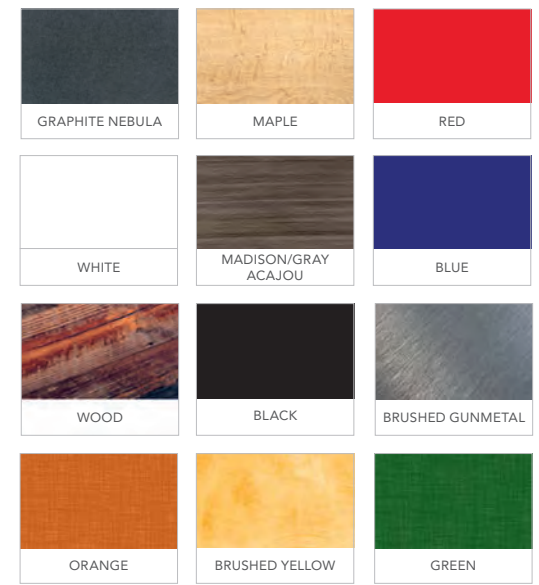

Bar Tables Standard Black Base 30" RND 42"H

- A) 8201221** (white)
 - B) 820919** (brushed yellow) also available
 - 820264** (Madison/gray acajou)
 - 820915** (brushed gunmetal)
 - 820916** (black)
 - 820917** (green)
 - 820918** (orange)
 - 820931** (blue)
 - 820933** (wood)
- 36" RND 42"H
8201241 (black)

Bar Tables Hydraulic Chrome Base 30" RND 45"H

- C) 820920** (red) also available
 - 8201207** (maple)
 - 820922** (graphite nebula)
 - 820910** (brushed gunmetal)
 - 820911** (black)
 - 820912** (green)
 - 820913** (orange)
 - 820914** (brushed yellow)
 - 820930** (blue)
 - 820932** (wood)
 - 8201236** (black)
- 36" RND 45"H
820125 (white)
8201211 (graphite nebula)
8201205 (maple)
8201240 (black)

Style & Design

Choose from a variety of table top colors and styles for the perfect look.



C) 720163 Chelsea Butcher Block-Top Bistro Table
(oak) 30" RND 42"H
also available
720164 36" RND 42"H

D) 81092 Lucent Barstool
(frosted, acrylic) 22"L 22.5"D 45.5"H

E) 72070 Soho Black-Top Bistro Table
(black) 24" RND 42"H
also available
72068 36" RND 42"H

F) 810953 Apex Barstool
(red vinyl) 21"L 21"D 33"H



Barstools



LIFT Barstools
 15" RND 23-33.5"H
A) 810870 (white vinyl)
B) 810873 (red vinyl)
C) 810871 (black vinyl)
D) 810872 (gray vinyl)

Styles & Shapes



Mix & Match
T) 720163 Butcher Block-Top Bistro
 (oak) 30"L RND 42"H
 also available **720164** 36" RND 42"H
U) 210109 LIMERICK® Stool BY HERMAN MILLER™
 (white) 18" X 17.75"L X 44"H

Apex Barstools
 21"L 21"D 33"H
A) 810951 (black vinyl)
B) 810953 (red vinyl)
C) 810954 (white vinyl)
D) 810952 (blue ultra suede)

Zoey Barstools
 15"L 16"D 30-34.75"H
E) 810840 (white, chrome)
F) 810834 (black, chrome)

Banana Barstools
 21"L 22"D 41.75"H
G) 810104 (black, chrome)
H) 810103 (white, chrome)

I) 810201 Oslo Barstool
 (white)
 17"L 20"D 45"H

J) 810848 Christopher Barstool
 (white vinyl, chrome)
 19"L 15"D 41"H

K) 810202 Shark Barstool
 (white, chrome)
 22"L 19"D 34-44"H

L) 810850 Zenith Barstool
 (white, chrome)
 19"L 20"D 44"H

M) 81092 Lucent Barstool
 (frosted, acrylic)
 22"L 22.5"D 45.5"H

N) 810860 Laguna Barstool
 (maple, chrome)
 18"L 20"D 47"H

Blade Barstool
 20.5"L 20.125"D 40.5"H
O) 81080 (red)
P) 81081 (sky blue)

Q) 71088 Black Diamond Stool
 (black) 22"W X 18"L X 46"H

R) Gas Lift Stool w/ arms
 24"W X 20"L X 46"H
71048 (gray, adjustable)
 also available
71047 w/o arms

S) 810839 Rustique Barstool
 (gunmetal) 13"L 13"D 30"H

Conference Tables

42" Round Conference Table
42" RND 29"H
A) 820708 (white laminate)
B) 820260 (Madison/gray acajou)
C) 8201244 (black top, black)



MADISON
(Madison/gray acajou)
C) 820261 5' Table
60"L 48"D 29"H
D) 820262 8' Table
96"L 60"D 29"H
E) 820263 10' Table
120"L 48"D 29"H



A) 810170 Cupertino Mid Back Chair
(black vinyl, chrome) 27"L 30.5"D 40-43"H Adjustable.
B) 810175 Genesis Chair
(black fabric, black) 27.5"L 27.5"D 40-43.5"H Adjustable.

Styles & Shapes



Pro Executive Mid Back Chair
24"L 22"D 40"H
A) 810945 (white vinyl)
B) 810944 (black vinyl)
Adjustable height

Atomic Round Tables
(glass, chrome)
C) 8201225 42" RND 30"H
D) 8201224 36" RND 30"H

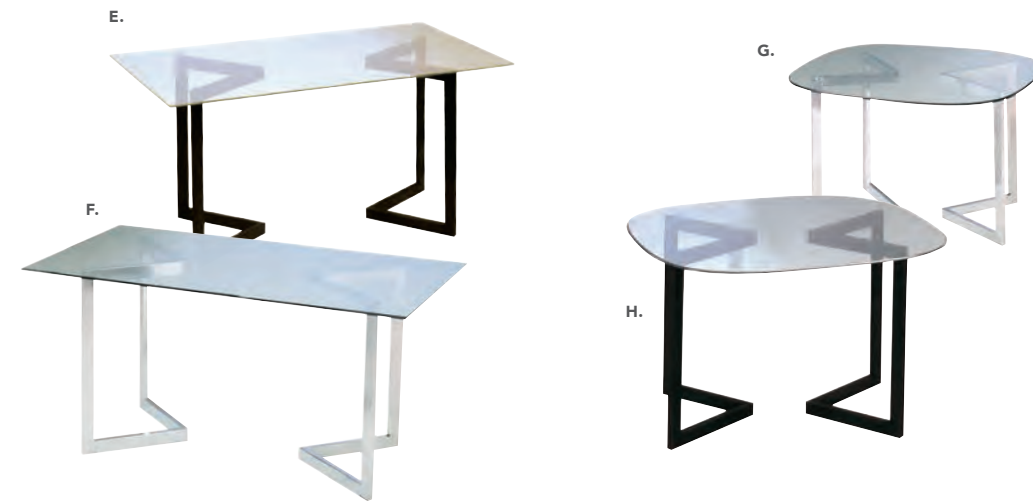

Geo Rectangular Tables
60"L 36"D 29"H
E) 82041 (glass, black)
F) 82051 (glass, chrome)

Geo Rounded Square Tables
42"L 42"D 29"H
G) 82044 (glass, chrome)
H) 82043 (glass, black)



I) 820203
6' Conference Tables
(graphite nebula)
72"L 42"D 29"H

J) 820707 Merlin
Multi Use Table
(gray laminate, black)
46"L 29"D 30"H
K) 820706 Work Table
(white laminate, white)
48"L 24"D 30"H

Executive Seating

Pro Executive High Back Chair

25"L 24"D 48"H
A) 810844 (white vinyl)
B) 810946 (black vinyl)
 Adjustable height



Cupertino Mid Back Chair

A) 810170 (black vinyl, chrome) 27"L 30.5"D 40-43"H Adjustable.
Genesis Chair
B) 810175 (black fabric, black) 27.5"L 27.5"D 40-43.5"H Adjustable.

Gas Lift Chair

26" X 20"L X 38"H
A) 71045 (gray, adjustable)
71046 w/ arms

Gas Lift Stool

24"W X 20"L X 46"H
B) 71048 (gray, adjustable)
71047 w/o arms



Pro Executive Mid Back Chair

24"L 22"D 40"H
A) 810945 (white vinyl)
B) 810944 (black vinyl)
 Adjustable height



Pro Executive Guest Chair

24"L 22"D 36"H
810947 (black vinyl)



Task Stool

810135
 (black fabric)
 27.5"L 27.5"D 32.75"-40.25"H
 Adjustable height



Communal and Powered Tables

Choose from a variety of powered, solid or grommet hole table tops.

Denotes AC and USB charging outlets



POWERED
DETAIL

Table Top Options



Colors not available in all table options. Please check options listed to the right.

Bar Tables



810860
Laguna Barstool
 (maple, chrome)
 18"L 20"D 47"H



Café Tables



Ventura Powered Bar Tables

(silver frame)
 72.25"L 26.25"D 42"H
A) 820950 (black top)
820955 (white top)

Ventura Communal Bar Tables

(silver frame)
 72.25"L 26.25"D 42"H

Maple Top
B) 820954 (solid)
820951 (grommets)

White Top
C) 820953 (grommets)
820956 (solid)

Black Top
820952 (solid)

Ventura Powered Café Tables

(silver frame)
 72.25"L 26.25"D 30"H
A) 820964 (black top)
B) 820965 (white top)

Ventura Communal Café Tables

(silver frame)
 72.25"L 26.25"D 30"H

Maple Top
C) 820963 (solid)
820960 (grommets)

White Top
D) 820961 (grommets)
820966 (solid)

Black Top
E) 820962 (solid)

Office Essentials

MADISON

A) 84075 Madison Executive Desk

(gray acajou) 60"L 30"D 29"H

B) 84077 Madison Credenza

(gray acajou) 60"L 20"D 29"H

C) 810135 Task Stool

(black fabric)

27.5"L 27.5"D 32.75"-40.25"H Adjustable

D) 810844 Pro Executive

High Back Chair

(white classic vinyl)

25"L 24"D 48"H Adjustable



Tech Powered Desk

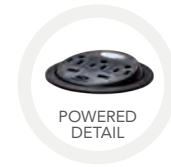

Denotes AC and USB charging outlets 

A) 84083 Tech Desk, Powered, w/ 3 Drawer File Cabinet

(black metal, laminate)
60"L 30"D 30"H

B) 84084 Tech Desk, Powered

(black metal, laminate)
60"L 30"D 30"H

C) 84080 3 Drawer File Cabinet on Castors

(black metal, laminate)
16"L 20"D 28"H

Lighting & Shelving



ACCENT LAMPS

Mason Lamps

(brushed silver)

A) 850708 Floor Lamp
18" RND 55"H

B) 850707 Table Lamp
16" RND 26"H

SHELVING

C) 85020

Posh Shelving

(chrome, acrylic)
36"L 18"D 72"H

D) 84078

Madison Bookcase

(gray acajou)
36"L 12"D 72"H

Show Essentials

Denotes AC and USB charging outlets 

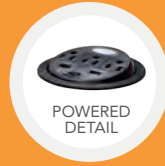

Midtown Powered Counter

Metallic pewter gray curved counter with taupe-colored glass top features two AC outlets, three USB charging outlets, locking storage cabinet and two shelves.

 **Midtown Powered Counter**
60"L 18"D 42"H (pewter/glass)
850103 (unlighted)
850102 (lighted with plug-in)



85030
7' Boxwood Hedge
36.5"L 12"D 84"H



810860
Laguna Barstool
(maple, chrome)
18"L 20"D 47"H

Display Counter

A) 72056
Display Counter
(black)
24"W X 49"L X 42"H

B) 210109
LIMERICK® Stool
BY HERMAN MILLER™
(white)
18" X 17.75" L X 44"H



Midtown Bar

Metallic pewter gray curved bar with taupe-colored glass top features locking cabinet for storage and two shelves.

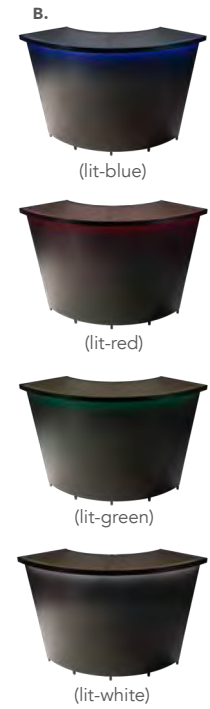

Midtown Bar
60"L 18"D 42"H
(pewter)
A) 850101
(unlighted)
B) 850100
(lighted with plug-in)

Apex Barstool
C) 810952
(blue ultra suede)
21"L 21"D 33"H

Lighted & Greenery Products

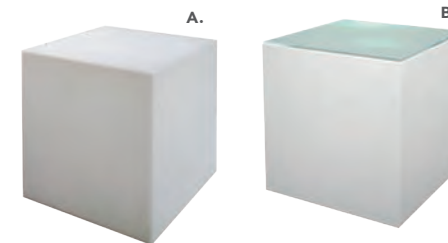

LED light available in white, red, green, blue and rolling color.

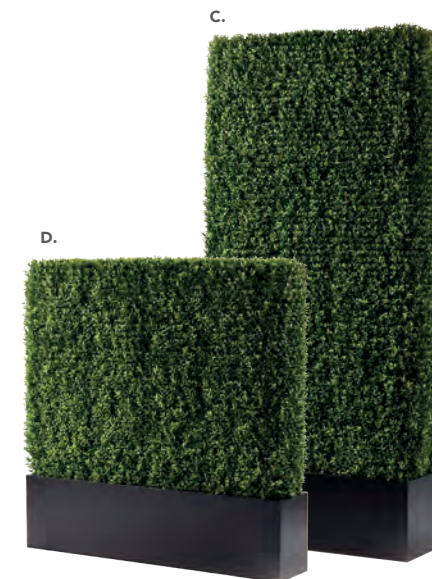

A) 81526 Edge
LED Cube Ottoman
(white plastic)
20"L 20"D 20"H
A/C power only
B) 82057 Edge LED
Cube Table
(plexi top, white plastic)
20"L 20"D 20"H
A/C power only

C) 85030
7' Boxwood Hedge
36.5"L 12"D 84"H
D) 85035
4' Boxwood Hedge
46"L 9"D 47"H

Draped or Undraped Tables & Counters

Table-Drape Colors



Special Draping: Special drape is available in a variety of colors. Refer to the order form for details. Table-top risers are available in a variety of sizes. See order form for details.

Visit us at freeman.com for ordering and full product line



Sizing Chart*

*Table and counter widths are available in select cities

24"D X 30"H | Tables Draped

124330	Tables Draped	3'L x 24"D x 30"H
124430	Tables Draped	4'L x 24"D x 30"H
124630	Tables Draped	6'L x 24"D x 30"H
124830	Tables Draped	8'L x 24"D x 30"H

24"D X 42"H | Counter Draped

124342	Counter Draped	3'L x 24"D x 42"H
124442	Counter Draped	4'L x 24"D x 42"H
124642	Counter Draped	6'L x 24"D x 42"H
124842	Counter Draped	8'L x 24"D x 42"H

24"D X 30"H | Tables Undraped

125330	Tables Undraped	3'L x 24"D x 30"H
125430	Tables Undraped	4'L x 24"D x 30"H
125630	Tables Undraped	6'L x 24"D x 30"H
125830	Tables Undraped	8'L x 24"D x 30"H

24"D X 42"H | Counter Undraped

125342	Counter Undraped	3'L x 24"D x 42"H
125442	Counter Undraped	4'L x 24"D x 42"H
125642	Counter Undraped	6'L x 24"D x 42"H
125842	Counter Undraped	8'L x 24"D x 42"H

30"D X 30"H | Tables Draped

130330	Tables Draped	3'L x 30"D x 30"H
130430	Tables Draped	4'L x 30"D x 30"H
130630	Tables Draped	6'L x 30"D x 30"H
130830	Tables Draped	8'L x 30"D x 30"H

30"D X 42"H | Counter Draped

130342	Counter Draped	3'L x 30"D x 42"H
130442	Counter Draped	4'L x 30"D x 42"H
130642	Counter Draped	6'L x 30"D x 42"H
130842	Counter Draped	8'L x 30"D x 42"H

30"D X 30"H | Tables Undraped

131330	Tables Undraped	3'L x 30"D x 30"H
131430	Tables Undraped	4'L x 30"D x 30"H
131630	Tables Undraped	6'L x 30"D x 30"H
131830	Tables Undraped	8'L x 30"D x 30"H

30"D X 42"H | Counter Undraped

131342	Counter Undraped	3'L x 30"D x 42"H
131442	Counter Undraped	4'L x 30"D x 42"H
131642	Counter Undraped	6'L x 30"D x 42"H
131842	Counter Undraped	8'L x 30"D x 42"H

4th Side | Table Draped 30"

12404630	Drape Table 4th Side	6' X 30"
12404830	Drape Table 4th Side	8' X 30"

4th Side | Table Draped 42"

12404642	Drape Table 4th Side	6' X 42"
12404842	Drape Table 4th Side	8' X 42"

Product Display



A) 72056
Display Counter
(black)
24"W X 49"L X 42"H



B) 75079
Orion Computer Kiosk
(black)
28"L X 28"D X 40.5"H
(computer not included)



C) 810840
Zoey Barstool
(white, chrome)
15"L 16"D 30-34.75"H



D) 75032
Display Cube-Large
(black)
24"W X 24"L X 42"H

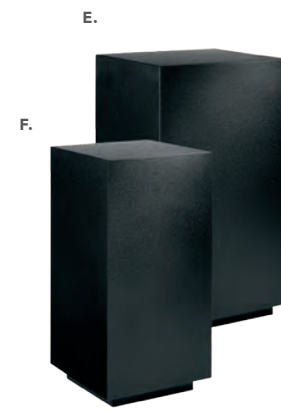

E) 75031
Display Cube-Medium
(black)
18"W X 18"L X 36"H

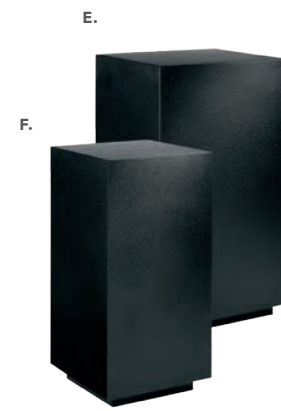

F) 75030
Display Cube-Small
(black)
12"W X 12"L X 42"H

G) 75022
Display Cylinder-High
(black)
24"W X 24"L X 36"H

H) 75021
Display Cylinder-Medium
(black)
18"W X 18"L X 20"H

I) 75020
Display Cylinder-Low
(black)
30"W X 12"L X 15"H

J) 810947
Pro Executive Guest Chair
(black vinyl)
24"L 22"D 36"H

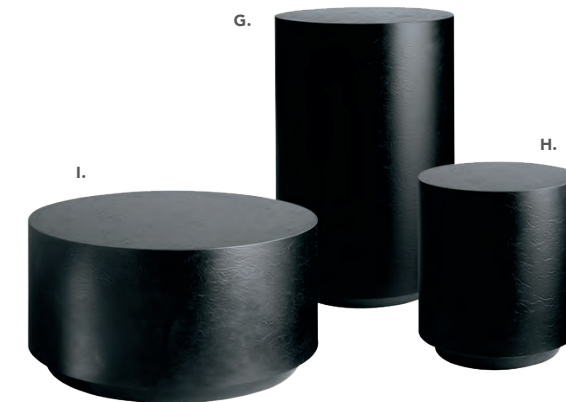

Product Storage



RACKS

A) 750135
Round Literature Rack
 (black)
 17"W X 17"L X 57"H

B) 750136
Flat Literature Rack
 (black)
 10"W X 55"H

CABINETS

C) 84080
3 Drawer File Cabinet
on Castors
 (black metal, laminate)
 16"L 20"D 28"H

D) 74082
2 Drawer File Cabinet
w/ Lock
 (tan metal)
 15"W X 29"L X 28"H

E) 74081
4 Drawer File Cabinet
w/ Lock
 (tan metal)
 15"W X 29"L X 50"H



REFRIGERATORS

F) 8503001
Large Refrigerator
 (white) 14.0 cubic feet
 28"W X 28"L X 64"H

G) 75057
Small Refrigerator
 4.0 cubic feet
 20"W X 22"L X 33"H

Show & Office Accessories

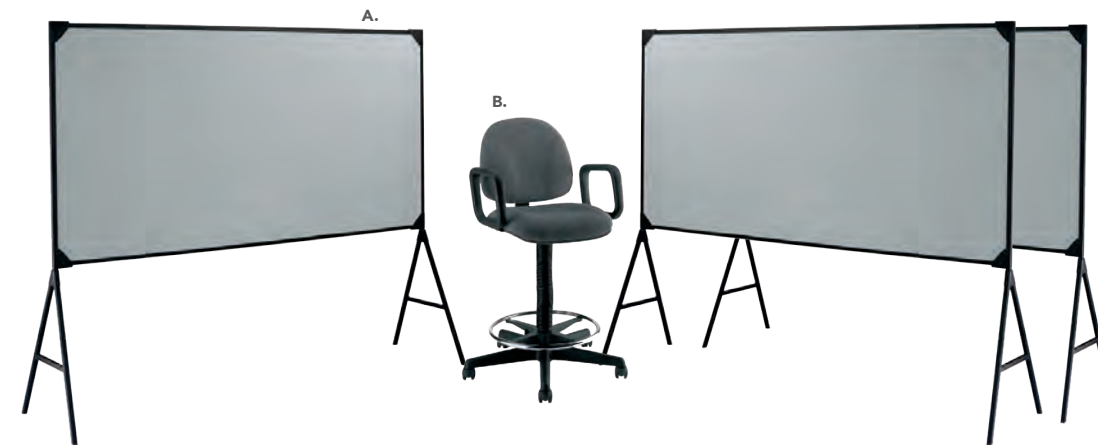

A) 10201484
Floor Standing
Bulletin Board
 (black)
 48"W X 96"L X 78"H

B) 71048
Gas Lift Stool w/ arms
 (gray, adjustable)
 24"W X 20"L X 46"H
 also available
71047 w/o arms



C) 220121
Chrome Stanchion
w/ 8' Retractable Belt
 (black, belt) 42"H

D) 220110
Chrome Bag Rack
 (3" at center)
 1"W X 41"H X 26"W

E) 220109
Chrome Coat Tree
 (21"w at the base)
 8 1/4"W X 69 1/2"H



F) 220118
Chrome Sign Holder
 (sign holds)
 22"W X 28"H

G) 220134
Brushed Aluminum Easel
 (open 5 1/4"W X 64 1/4"H)
 26"W X 62"H

H) 220106
Corrugated Wastebasket
 (black)

FREEMAN

(888) 508-5054 Fax: (469) 621-5612
 ExhibitorSupport@freeman.com

ONLINE PRICE
 DISCOUNT PRICE
 DEADLINE DATE
 MAY 04, 2021

NAME OF SHOW: **New Cardiovascular Horizons Conference / June 2 - 4, 2021**

COMPANY NAME: _____ BOOTH #: _____

CONTACT NAME : _____ PHONE #: _____

E-MAIL ADDRESS : _____

Take advantage of the Online price by ordering at www.freeman.com/store by the deadline date.

Qty	Part #	Description	Online Price	Discount Price	Standard Price	Total
SOFT SEATING						

Naples Group - Black Vinyl						
_____	810119	Chair.....	516.50	568.15	723.10	_____
_____	830120	Loveseat.....	694.30	763.75	972.00	_____
_____	830119	Sofa.....	768.80	845.70	1,076.30	_____

Munich Group - Gray Fabric						
_____	810151	Armless Chair.....	510.45	561.50	714.65	_____

Baja Group - White Vinyl						
_____	81050	Chair.....	547.70	602.45	766.80	_____
_____	83020	Loveseat.....	602.45	662.70	843.45	_____
_____	83019	Sofa.....	792.95	872.25	1,110.15	_____

Valencia - Velvet						
_____	810180	Chair - Spice Orange.....	349.00	383.90	488.60	_____
_____	83045	Sofa - Coffee Brown.....	524.50	576.95	734.30	_____

Key Largo Group - Black Fabric						
_____	830950	Loveseat.....	533.35	586.70	746.70	_____
_____	830951	Sofa.....	590.20	649.20	826.30	_____
_____	810950	Chair.....	420.50	462.55	588.70	_____

Allegro Group - Blue Fabric						
_____	81019	Chair.....	544.10	598.50	761.75	_____
_____	83015	Sofa.....	868.50	955.35	1,215.90	_____

Fairfax Group - White Vinyl						
_____	810949	Chair.....	354.65	390.10	496.50	_____
_____	830949	Sofa.....	565.95	622.55	792.35	_____

Palm Beach - White Vinyl						
_____	83040	Sofa.....	598.85	658.75	838.40	_____

Sterling Group - Gray Fabric						
_____	81037	Chair.....	820.00	902.00	1,148.00	_____
_____	8309	Sofa.....	1,224.00	1,346.40	1,713.60	_____

CASUAL SEATING						
Ottomans						
_____	815122	Endless Square - White Vinyl.....	331.55	364.70	464.15	_____
_____	815123	Endless Square - Black Vinyl.....	331.55	364.70	464.15	_____
_____	815953	Endless Curve - White Vinyl.....	438.05	481.85	613.25	_____
_____	815952	Endless Curve - Black Vinyl.....	438.05	481.85	613.25	_____
_____	81518	Vibe Cube - Blue Vinyl.....	154.75	170.25	216.65	_____
_____	81519	Vibe Cube - Red Vinyl.....	154.75	170.25	216.65	_____
_____	81525	Vibe Cube - Orange Vinyl.....	154.75	170.25	216.65	_____
_____	81517	Vibe Cube - Yellow Vinyl.....	154.75	170.25	216.65	_____
_____	81530	Vibe Cube - Black Vinyl.....	126.35	139.00	176.90	_____
_____	81531	Vibe Cube - White Vinyl.....	126.35	139.00	176.90	_____
_____	81532	Vibe Cube - Steel Blue Vinyl.....	154.75	170.25	216.65	_____

NAME OF SHOW: **New Cardiovascular Horizons Conference / June 2 - 4, 2021**

COMPANY NAME:

BOOTH #:

CONTACT NAME :

PHONE #:

E-MAIL ADDRESS :

Take advantage of the Online price by ordering at www.freeman.com/store by the deadline date.

furnishings

Qty	Part #	Description	Online Price	Discount Price	Standard Price	Total
Ottomans (continued)						
_____	81533	Vibe Cube - Silver Vinyl.....	154.75	170.25	216.65	_____
_____	81534	Vibe Cube - Purple Vinyl.....	154.75	170.25	216.65	_____
_____	81535	Vibe Cube -Citrus Green Vinyl.....	154.75	170.25	216.65	_____
_____	81536	Vibe Cube - Taupe Vinyl.....	154.75	170.25	216.65	_____
_____	81537	Vibe Cube - Spice Orange Vinyl.....	154.75	170.25	216.65	_____
_____	81538	Vibe Cube - Desert Rose Vinyl.....	154.75	170.25	216.65	_____
_____	815151	Marche Swivel - Gray Fabric.....	223.40	245.75	312.75	_____
_____	815154	Marche Swivel - Red Fabric.....	223.40	245.75	312.75	_____
_____	815159	Marche Swivel - Blue Fabric.....	223.40	245.75	312.75	_____
_____	815152	Marche Swivel - Linen Fabric.....	223.40	245.75	312.75	_____
_____	815157	Marche Swivel - Meadow Green Fabric.....	223.40	245.75	312.75	_____
_____	815158	Marche Swivel - Pear Yellow Fabric.....	223.40	245.75	312.75	_____
_____	815156	Marche Swivel - Plum Fabric.....	223.40	245.75	312.75	_____
_____	815153	Marche Swivel - Raspberry Fabric.....	223.40	245.75	312.75	_____
_____	815155	Marche Swivel - Rose Quartz Fabric.....	223.40	245.75	312.75	_____
_____	815150	Marche Swivel - White Vinyl.....	223.40	245.75	312.75	_____
_____	815160	Marche Swivel - Orange Fabric.....	214.75	236.25	300.65	_____
_____	81540	Marche Swivel - Forest Green Vinyl.....	N/A	N/A	N/A	_____
_____	81541	Marche Swivel - Teal Velvet.....	208.55	229.40	291.95	_____
_____	81542	Marche Swivel - Distressed Brown Vinyl.....	208.55	229.40	291.95	_____
_____	81543	Marche Swivel - Black Vinyl.....	208.55	229.40	291.95	_____
_____	81539	Marche Swivel - Ivory Faux Sheep Fur.....	208.55	229.40	291.95	_____
Beverly Bench Ottomans						
_____	81550	Black Vinyl.....	433.80	477.20	607.30	_____
_____	81551	Brown Fabric.....	433.80	477.20	607.30	_____
_____	81552	Gray Fabric.....	433.80	477.20	607.30	_____
_____	81553	Linen Fabric.....	433.80	477.20	607.30	_____
_____	81554	Ocean Blue Fabric.....	433.80	477.20	607.30	_____
_____	81555	Red Fabric.....	433.80	477.20	607.30	_____
_____	81556	White Vinyl.....	433.80	477.20	607.30	_____
Beverly Small Bench Ottomans						
_____	81560	Black Vinyl.....	382.00	420.20	534.80	_____
_____	81561	Blue Fabric.....	382.00	420.20	534.80	_____
_____	81562	Brown Fabric.....	382.00	420.20	534.80	_____
_____	81563	Green Fabric.....	382.00	420.20	534.80	_____
_____	81565	Linen Fabric.....	382.00	420.20	534.80	_____
_____	81568	Red Fabric.....	382.00	420.20	534.80	_____
_____	81569	White Vinyl.....	382.00	420.20	534.80	_____
_____	81566	Lavender Fabric.....	382.00	420.20	534.80	_____
_____	81567	Orange Fabric.....	382.00	420.20	534.80	_____
_____	81564	Gray Fabric.....	382.00	420.20	534.80	_____
_____	81570	Yellow Fabric.....	382.00	420.20	534.80	_____
Accent Chairs						
_____	71089	Black Diamond Side Chair.....	133.25	146.60	186.55	_____
_____	71090	Black Diamond Arm Chair.....	158.40	174.25	221.75	_____
_____	810861	Laguna Chair - Maple/Chrome.....	133.60	146.95	187.05	_____
_____	210108	Limerick® Chair by Herman Miller.....	79.50	87.45	111.30	_____

NAME OF SHOW: **New Cardiovascular Horizons Conference / June 2 - 4, 2021**

COMPANY NAME: _____ BOOTH #: _____

CONTACT NAME : _____ PHONE #: _____

E-MAIL ADDRESS : _____

Take advantage of the Online price by ordering at www.freeman.com/store by the deadline date.

Qty	Part #	Description	Online Price	Discount Price	Standard Price	Total
Accent Chairs (continued)						
_____	810816	Madrid Chair - White Vinyl/Chrome.....	861.05	947.15	1,205.45	_____
_____	810948	Meeting Chair - White Vinyl.....	292.05	321.25	408.85	_____
_____	810164	Marina Chair - White Vinyl.....	138.35	152.20	193.70	_____
_____	810160	Marina Chair - Black Vinyl.....	138.35	152.20	193.70	_____
_____	810161	Marina Chair - Brown Fabric.....	138.35	152.20	193.70	_____
_____	810162	Marina Chair - Ocean Blue Fabric.....	138.35	152.20	193.70	_____
_____	810163	Marina Chair - Red Fabric.....	138.35	152.20	193.70	_____
_____	810131	Malba Chair - Gray Molded Plastic.....	99.25	109.20	138.95	_____
_____	810130	Malba Chair - Green Molded Plastic.....	99.25	109.20	138.95	_____
_____	810846	Christopher Chair - White Vinyl/Chrome.....	129.70	142.65	181.60	_____
_____	810851	Zenith Chair - White/Chrome.....	155.70	171.25	218.00	_____
_____	810841	Rustique Chair - Gunmetal.....	129.70	142.65	181.60	_____
_____	810837	Razor Armless Chair - White High Density Plastic.....	56.10	61.70	78.55	_____
_____	810875	Swanson Swivel Chair - White Vinyl.....	281.10	309.20	393.55	_____
_____	81083	Blade Chair - Sky Blue.....	76.40	84.05	106.95	_____
_____	81082	Blade Chair - Red.....	76.40	84.05	106.95	_____
_____	81093	Lucent Chair - Frosted Acrylic.....	192.05	211.25	268.85	_____
_____	810145	Wentworth Chair - Brown Vinyl.....	245.75	270.35	344.05	_____
_____	81024	Atherton Chair - Brown Leather.....	732.00	805.20	1,024.80	_____
_____	81034	Bowery Chair - Yellow Fabric.....	508.00	558.80	711.20	_____
_____	81035	Century Chair - Gray Velvet.....	492.00	541.20	688.80	_____
_____	81036	Lena Chair - Green Leather.....	620.00	682.00	868.00	_____
_____	81031	Montreal Chair - Blue Fabric.....	570.00	627.00	798.00	_____
_____	81032	Pasadena Chair - White Plastic.....	318.00	349.80	445.20	_____
_____	81038	Tech Chair - Gray Vinyl.....	378.00	415.80	529.20	_____
_____	81039	Tech Tablet Chair - Gray Vinyl.....	378.00	415.80	529.20	_____
Executive Seating						
_____	71046	Gray Gaslift Chair With Arms.....	242.35	266.60	339.30	_____
_____	71045	Gray Gaslift Chair Without Arms.....	207.75	228.55	290.85	_____
_____	810874	La Brea Swivel Chair - Charcoal Gray Fabric.....	331.55	364.70	464.15	_____
_____	810175	Genesis Chair - Black.....	377.90	415.70	529.05	_____
_____	810844	Pro Executive High Back Chair - White Vinyl.....	289.40	318.35	405.15	_____
_____	810946	Pro Executive High Back Chair - Black Vinyl.....	289.40	318.35	405.15	_____
_____	810945	Pro Executive Mid Back Chair - White Vinyl.....	347.50	382.25	486.50	_____
_____	810944	Pro Executive Mid Back Chair - Black Vinyl.....	347.50	382.25	486.50	_____
_____	810947	Pro Executive Guest Chair - Black Vinyl.....	377.85	415.65	529.00	_____
_____	810170	Cupertino Mid Back Chair - Black Vinyl.....	436.75	480.45	611.45	_____
Barstools						
_____	71088	Black Diamond Stool.....	199.05	218.95	278.65	_____
_____	71048	Gray Gaslift Stool with Arms.....	311.55	342.70	436.15	_____
_____	71047	Gray Gaslift Stool without Arms.....	280.40	308.45	392.55	_____
_____	810860	Laguna Barstool - Maple/Chrome.....	168.65	185.50	236.10	_____
_____	210109	Limerick® Stool by Herman Miller.....	131.80	145.00	184.50	_____
_____	810872	Lift Barstool - Gray Vinyl/Chrome.....	170.50	187.55	238.70	_____
_____	810873	Lift Barstool - Red Vinyl/Chrome.....	170.50	187.55	238.70	_____
_____	810871	Lift Barstool - Black Vinyl/Chrome.....	170.50	187.55	238.70	_____
_____	810870	Lift Barstool - White Vinyl/Chrome.....	170.50	187.55	238.70	_____
_____	810103	Banana Barstool - White Vinyl/Chrome.....	197.55	217.30	276.55	_____

NAME OF SHOW: **New Cardiovascular Horizons Conference / June 2 - 4, 2021**

COMPANY NAME: _____ BOOTH #: _____

CONTACT NAME : _____ PHONE #: _____

E-MAIL ADDRESS : _____

Take advantage of the Online price by ordering at www.freeman.com/store by the deadline date.

Qty	Part #	Description	Online Price	Discount Price	Standard Price	Total
Barstools (continued)						
_____	810104	Banana Barstool - Black Vinyl/Chrome.....	197.55	217.30	276.55	_____
_____	810850	Zenith Barstool - White/Chrome.....	155.70	171.25	218.00	_____
_____	810840	Zoey Barstool - White Vinyl/Chrome.....	319.50	351.45	447.30	_____
_____	810848	Christopher Barstool - White Vinyl/Chrome.....	216.75	238.45	303.45	_____
_____	810202	Shark Swivel Barstool - White Plastic/Chrome.....	364.45	400.90	510.25	_____
_____	810839	Rustique Barstool - Gunmetal.....	129.70	142.65	181.60	_____
_____	81080	Blade Barstool - Red.....	152.80	168.10	213.90	_____
_____	81081	Blade Barstool - Sky Blue.....	152.80	168.10	213.90	_____
_____	81092	Lucent Barstool - Frosted Acrylic.....	204.45	224.90	286.25	_____
_____	810135	Task Stool - Black Fabric.....	169.35	186.30	237.10	_____
_____	81026	Marina Barstool - Ocean Blue.....	264.00	290.40	369.60	_____
_____	81027	Marina Barstool - Black Vinyl.....	264.00	290.40	369.60	_____
_____	81028	Marina Barstool - Brown Fabric.....	264.00	290.40	369.60	_____
_____	81029	Marina Barstool - Red Fabric.....	264.00	290.40	369.60	_____
_____	81030	Marina Barstool - White Vinyl.....	264.00	290.40	369.60	_____

Draped Tables & Counters

Draped Tables - Tables are 24" wide <input type="checkbox"/> Black <input type="checkbox"/> Blue <input type="checkbox"/> White <input type="checkbox"/> Gray <input type="checkbox"/> Red
--

_____	124330	Draped Table 3'L x 30"H.....	127.50	140.25	178.50	_____
_____	124430	Draped Table 4'L x 30"H.....	145.05	159.55	203.05	_____
_____	124630	Draped Table 6'L x 30"H.....	209.95	230.95	293.95	_____
_____	124830	Draped Table 8'L x 30"H.....	222.95	245.25	312.15	_____
_____	12404630	4th Side Drape 6'L x 30"H.....	43.20	47.50	60.50	_____
_____	12404830	4th Side Drape 8'L x 30"H.....	43.20	47.50	60.50	_____
_____	124342	Draped Counter 3'L x 42"H.....	169.90	186.90	237.85	_____
_____	124442	Draped Counter 4'L x 42"H.....	210.30	231.35	294.40	_____
_____	124642	Draped Counter 6'L x 42"H.....	212.45	233.70	297.45	_____
_____	124842	Draped Counter 8'L x 42"H.....	246.35	271.00	344.90	_____
_____	12404642	4th Side Drape 6'L x 42"H.....	43.20	47.50	60.50	_____
_____	12404842	4th Side Drape 8'L x 42"H.....	43.20	47.50	60.50	_____

Undraped Tables & Counters

_____	125330	Undraped Table 3'L x 30"H.....	59.40	65.35	83.15	_____
_____	125430	Undraped Table 4'L x 30"H.....	66.70	73.35	93.40	_____
_____	125630	Undraped Table 6'L x 30"H.....	76.45	84.10	107.05	_____
_____	125830	Undraped Table 8'L x 30"H.....	84.95	93.45	118.95	_____
_____	125342	Undraped Counter 3'L x 42"H.....	84.95	93.45	118.95	_____
_____	125442	Undraped Counter 4'L x 42"H.....	102.00	112.20	142.80	_____
_____	125642	Undraped Counter 6'L x 42"H.....	118.95	130.85	166.55	_____
_____	125842	Undraped Counter 8'L x 42"H.....	135.90	149.50	190.25	_____

Table Top Risers - Risers are 8" wide

_____	1504100	Black 4'L x 7"H Corrugated Riser.....	29.25	32.20	40.95	_____
_____	1504101	White 4'L x 7"H Corrugated Riser.....	29.25	32.20	40.95	_____
_____	1506100	Black 6'L x 7"H Corrugated Riser.....	34.25	37.70	47.95	_____
_____	1506101	White 6'L x 7"H Corrugated Riser.....	34.25	37.70	47.95	_____
_____	1508100	Black 8'L x 7"H Corrugated Riser.....	39.50	43.45	55.30	_____
_____	1508101	White 8'L x 7"H Corrugated Riser.....	39.50	43.45	55.30	_____

furnishings

NAME OF SHOW: **New Cardiovascular Horizons Conference / June 2 - 4, 2021**

COMPANY NAME: _____ BOOTH #: _____

CONTACT NAME : _____ PHONE #: _____

E-MAIL ADDRESS : _____

Take advantage of the Online price by ordering at www.freeman.com/store by the deadline date.

Qty	Part #	Description	Online Price	Discount Price	Standard Price	Total
Table Top Risers - Risers are 8" wide (continued)						
_____	1504200	Black 4'L x 14"H Corrugated Riser.....	44.75	49.25	62.65	_____
_____	1504201	White 4'L x 14"H Corrugated Riser.....	44.75	49.25	62.65	_____
_____	1506200	Black 6'L x 14"H Corrugated Riser.....	54.75	60.25	76.65	_____
_____	1506201	White 6'L x 14"H Corrugated Riser.....	54.75	60.25	76.65	_____
_____	1508200	Black 8'L x 14"H Corrugated Riser.....	64.75	71.25	90.65	_____
_____	1508201	White 8'L x 14"H Corrugated Riser.....	64.75	71.25	90.65	_____
Pedestal Tables - Soho Series						
_____	72069	Black Top Cafe Table - 30"H x 24"W.....	227.50	250.25	318.50	_____
_____	72067	Black Top Cafe Table - 30"H x 36"W.....	227.50	250.25	318.50	_____
_____	72066	Black Top Mini Table - 18"H x 18"W.....	138.45	152.30	193.85	_____
_____	72070	Black Top Bistro Table - 42"H x 24"W.....	227.50	250.25	318.50	_____
_____	72068	Black Top Bistro Table - 42"H x 36"W.....	227.50	250.25	318.50	_____
Pedestal Tables - Chelsea Series						
_____	72063	Butcher Block Top Cafe Table - 30"H x 30"W.....	216.25	237.90	302.75	_____
_____	72064	Butcher Block Top Cafe Table - 30"H x 36"W.....	216.25	237.90	302.75	_____
_____	720163	Butcher Block Top Bistro Table - 42"H x 30"W.....	216.25	237.90	302.75	_____
_____	720164	Butcher Block Top Bistro Table - 42"H x 36"W.....	216.25	237.90	302.75	_____
Pedestal Tables						
_____	8201208	Hydraulic Base Cafe Table - Maple.....	350.55	385.60	490.75	_____
_____	8201207	Hydraulic Base Bar Table - Maple.....	350.55	385.60	490.75	_____
_____	8201209	Hydraulic Base Cafe Table - Graphite.....	385.60	424.15	539.85	_____
_____	8201211	Hydraulic Base Bar Table - Graphite.....	385.60	424.15	539.85	_____
_____	8201206	Hydraulic Base Cafe Table - Maple.....	383.35	421.70	536.70	_____
_____	8201205	Hydraulic Base Bar Table - Maple.....	383.35	421.70	536.70	_____
_____	820126	Hydraulic Base Cafe Table - White Laminate.....	400.90	441.00	561.25	_____
_____	820125	Hydraulic Base Bar Table - White Laminate.....	400.90	441.00	561.25	_____
_____	820241	Madison Hydraulic Base Cafe Table - Gray Acajou.	309.10	340.00	432.75	_____
_____	820240	Madison Hydraulic Base Bar Table - Gray Acajou...	309.10	340.00	432.75	_____
_____	820265	Madison Cafe Table - Gray Acajou.....	251.95	277.15	352.75	_____
_____	820264	Madison Bar Table - Gray Acajou.....	251.95	277.15	352.75	_____
_____	8201220	30" Cafe Table Black Base - White Laminate.....	251.95	277.15	352.75	_____
_____	8201221	30" Bar Table Black Base - White Laminate.....	269.50	296.45	377.30	_____
_____	8201222	30" Bar Table Chrome Base - White Laminate.....	387.75	426.55	542.85	_____
_____	8201223	30" Cafe Table Chrome Base - White Laminate.....	387.75	426.55	542.85	_____
_____	820920	30" Bar Table Chrome Hydraulic Base - Red.....	300.10	330.10	420.15	_____
_____	820921	30" Cafe Table Chrome Hydraulic Base - Red.....	300.10	330.10	420.15	_____
_____	820922	30" Bar Table Chrome Hydraulic Base - Graphite....	300.10	330.10	420.15	_____
_____	820923	30" Cafe Table Chrome Hydraulic Base - Graphite....	300.10	330.10	420.15	_____
_____	820930	30" Bar Table w/ Hydraulic Base - Blue.....	282.90	311.20	396.05	_____
_____	820931	30" Bar Table w/ Black Base - Blue.....	225.10	247.60	315.15	_____
_____	820932	30" Bar Table w/ Hydraulic Base - Wood.....	344.85	379.35	482.80	_____
_____	820933	30" Bar Table w/ Black Base - Wood.....	239.55	263.50	335.35	_____
_____	820940	30" Cafe Table w/ Hydraulic Base - Blue.....	282.90	311.20	396.05	_____
_____	820941	30" Cafe Table w/ Black Base - Blue.....	202.35	222.60	283.30	_____
_____	820942	30" Cafe Table w/ Hydraulic Base - Wood.....	344.85	379.35	482.80	_____

NAME OF SHOW: **New Cardiovascular Horizons Conference / June 2 - 4, 2021**

COMPANY NAME: _____ BOOTH #: _____

CONTACT NAME : _____ PHONE #: _____

E-MAIL ADDRESS : _____

Take advantage of the Online price by ordering at www.freeman.com/store by the deadline date.

Qty	Part #	Description	Online Price	Discount Price	Standard Price	Total
Pedestal Tables (continued)						
_____	820943	30" Cafe Table w/ Black Base - Wood.....	218.90	240.80	306.45	_____
_____	820910	30" Bar Table w/ Hydraulic Base - Gunmetal.....	371.70	408.85	520.40	_____
_____	820911	30" Bar Table w/ Hydraulic Base - Black.....	371.70	408.85	520.40	_____
_____	820912	30" Bar Table w/ Hydraulic Base - Green.....	371.70	408.85	520.40	_____
_____	820913	30" Bar Table w/ Hydraulic Base - Orange.....	371.70	408.85	520.40	_____
_____	820914	30" Bar Table w/ Hydraulic Base - Yellow.....	371.70	408.85	520.40	_____
_____	820915	30" Bar Table w/ Black Base - Gunmetal.....	260.20	286.20	364.30	_____
_____	820916	30" Bar Table w/ Black Base - Black.....	260.20	286.20	364.30	_____
_____	820917	30" Bar Table w/ Black Base - Green.....	260.20	286.20	364.30	_____
_____	820918	30" Bar Table w/ Black Base - Orange.....	260.20	286.20	364.30	_____
_____	820919	30" Bar Table w/ Black Base - Yellow.....	260.20	286.20	364.30	_____
_____	8201230	30" Cafe Table w/ Hydraulic Base - Gunmetal.....	371.70	408.85	520.40	_____
_____	8201231	30" Cafe Table w/ Hydraulic Base - Black.....	371.70	408.85	520.40	_____
_____	8201232	30" Cafe Table w/ Hydraulic Base - Green.....	371.70	408.85	520.40	_____
_____	8201233	30" Cafe Table w/ Hydraulic Base - Orange.....	371.70	408.85	520.40	_____
_____	8201234	30" Cafe Table w/ Hydraulic Base - Yellow.....	371.70	408.85	520.40	_____
_____	8201235	30" Cafe Table w/ Black Base - Gunmetal.....	241.60	265.75	338.25	_____
_____	8201236	30" Cafe Table w/ Black Base - Black.....	241.60	265.75	338.25	_____
_____	8201237	30" Cafe Table w/ Back Base - Green.....	241.60	265.75	338.25	_____
_____	8201238	30" Cafe Table w/ Black Base - Orange.....	241.60	265.75	338.25	_____
_____	8201239	30" Cafe Table w/ Black Base - Yellow.....	241.60	265.75	338.25	_____
_____	8201240	36" Bar Table w/ Hydraulic Base - Black.....	386.15	424.75	540.60	_____
_____	8201241	36" Bar Table w// Black Base - Black.....	264.30	290.75	370.00	_____
_____	8201242	36" Cafe Table w/ Hydraulic Base - Black.....	367.55	404.30	514.55	_____
_____	8201243	36" Cafe Table w// Black Base - Black.....	282.90	311.20	396.05	_____
Accent Tables						
_____	82015	Silverado End Table - Tempered Glass/Painted Steel.....	266.00	292.60	372.40	_____
_____	82014	Silverado Cocktail Table - Tempered Glass/Painted Steel.....	282.65	310.90	395.70	_____
_____	820252	Alondra End Table - Glass/Chrome.....	225.65	248.20	315.90	_____
_____	820250	Alondra Cocktail Table - Glass/Chrome.....	313.65	345.00	439.10	_____
_____	820253	Alondra End Table - Wood/Chrome.....	225.65	248.20	315.90	_____
_____	820251	Alondra Cocktail Table - Wood/Chrome.....	313.65	345.00	439.10	_____
_____	8201224	Atomic 36" Round Table - Glass/Chrome.....	343.95	378.35	481.55	_____
_____	8201225	Atomic 42" Round Table - Glass/Chrome.....	343.95	378.35	481.55	_____
_____	82028	Geo End Table - Wood/Black Steel.....	266.30	292.95	372.80	_____
_____	82027	Geo Cocktail Table - Wood/Black Steel.....	273.05	300.35	382.25	_____
_____	82035	Geo End Table - Glass/Chrome.....	240.25	264.30	336.35	_____
_____	82034	Geo Cocktail Table - Glass/Chrome.....	266.00	292.60	372.40	_____
_____	82054	Sydney End Table - Black Laminate/Brushed Steel..	247.80	272.60	346.90	_____
_____	82055	Sydney End Table - White Laminate/Brushed Steel..	247.80	272.60	346.90	_____
_____	82052	Sydney Cocktail Table - Black Laminate/Brushed Steel.....	299.50	329.45	419.30	_____
_____	82053	Sydney Cocktail Table - White Laminate/Brushed Steel.....	299.50	329.45	419.30	_____
_____	82079	Sydney End Table - Blue Laminate/Brushed Steel.....	220.95	243.05	309.35	_____
_____	82080	Sydney End Table - Wood Laminate/Brushed Steel..	220.95	243.05	309.35	_____
_____	82077	Sydney Cocktail Table - Blue Laminate/Brushed Steel.....	266.40	293.05	372.95	_____

NAME OF SHOW: **New Cardiovascular Horizons Conference / June 2 - 4, 2021**

COMPANY NAME:

BOOTH #:

CONTACT NAME :

PHONE #:

E-MAIL ADDRESS :

Take advantage of the Online price by ordering at www.freeman.com/store by the deadline date.

Qty	Part #	Description	Online Price	Discount Price	Standard Price	Total
Accent Tables (continued)						
	82078	Sydney Cocktail Table - Wood Laminate/Brushed Steel.....	266.40	293.05	372.95	
	82075	Regis End Table - Brushed Metal.....	245.95	270.55	344.35	
	82074	Regis Bench Table - Brushed Metal.....	347.70	382.45	486.80	
	820844	Aura Round Table - White Metal.....	136.90	150.60	191.65	
	82043	Geo Square-Round Table - Glass/Black Steel.....	323.85	356.25	453.40	
	82044	Geo Square-Round Table - Glass/Chrome.....	323.85	356.25	453.40	
	8201226	Rustique Square Metal Bar Table - Gray.....	297.95	327.75	417.15	
	820130	Mesa Cocktail Table - Black/Bronze.....	272.60	299.85	381.65	
	820131	Mesa Cocktail Table - Glass/Bronze.....	272.60	299.85	381.65	
	820132	Mesa Cocktail Table - Wood/Bronze.....	272.60	299.85	381.65	
	820133	Mesa End Table - Black/Bronze.....	242.65	266.90	339.70	
	820134	Mesa End Table - Glass/Bronze.....	242.65	266.90	339.70	
	820135	Mesa End Table - Wood/Bronze.....	242.65	266.90	339.70	
	820310	Sedona Side Table - Black/Bronze.....	201.35	221.50	281.90	
	820311	Sedona Side Table - Wood/Bronze.....	201.35	221.50	281.90	
	820312	Sedona Side Table - White/Bronze.....	201.35	221.50	281.90	
	820320	Taos Side Table - Black/Bronze.....	201.35	221.50	281.90	
	820321	Taos Side Table Wood/Bronze.....	201.35	221.50	281.90	
	820322	Taos Side Table - White/Bronze.....	201.35	221.50	281.90	
Conference Tables						
	82041	Geo Conference Table - Glass/Black Steel.....	448.40	493.25	627.75	
	82051	Geo Conference Table - Glass/Chrome.....	448.40	493.25	627.75	
	820260	Madison Conference Table - Gray Acajou.....	417.50	459.25	584.50	
	820708	42" Round Conference Table - White Laminate.....	430.10	473.10	602.15	
	820261	Madison 5' Conference Table - Gray Acajou.....	505.45	556.00	707.65	
	820262	Madison 8' Conference Table - Gray Acajou.....	1,008.60	1,109.45	1,412.05	
	820263	Madison 10' Conference Table - Gray Acajou.....	1,008.60	1,109.45	1,412.05	
	820951	Ventura Bar Table - Maple w/ Grommets.....	696.70	766.35	975.40	
	820952	Ventura Communal Bar Table - Black.....	718.55	790.40	1,005.95	
	820953	Ventura Bar Table - White w/ Grommets.....	696.70	766.35	975.40	
	820954	Ventura Communal Bar Table - Maple.....	696.70	766.35	975.40	
	820956	Ventura Communal Bar Table - White.....	696.70	766.35	975.40	
	820963	Ventura Communal Cafe Table - Maple.....	468.75	515.65	656.25	
	820960	Ventura Cafe Table - Maple w/ Grommets.....	656.65	722.30	919.30	
	820961	Ventura Cafe Table - White w/ Grommets.....	656.65	722.30	919.30	
	820966	Ventura Communal Cafe Table - White.....	468.75	515.65	656.25	
	820962	Ventura Communal Cafe Table - Black.....	468.75	515.65	656.25	
	8201244	42" Round Conference Table - Black Laminate.....	384.10	422.50	537.75	
	8201	10' Table - Black Laminate.....	808.00	888.80	1,131.20	
	8203	5' Table - Black Laminate.....	416.00	457.60	582.40	
	8205	8' Table - Black Laminate.....	608.00	668.80	851.20	
Office						
	84075	Madison Desk - Gray Acajou.....	617.20	678.90	864.10	
	84078	Madison Bookcase - Gray Acajou.....	438.80	482.70	614.30	

furnishings

NAME OF SHOW: **New Cardiovascular Horizons Conference / June 2 - 4, 2021**

COMPANY NAME: _____ BOOTH #: _____

CONTACT NAME : _____ PHONE #: _____

E-MAIL ADDRESS : _____

Take advantage of the Online price by ordering at www.freeman.com/store by the deadline date.

Qty	Part #	Description	Online Price	Discount Price	Standard Price	Total
Computer Desks/Tables						
	820706	Work Desk - White Laminate.....	370.00	407.00	518.00	
POWERED						
Powered Seating						
	810120	Naples Chair, Powered - Black Vinyl.....	697.85	767.65	977.00	
	830122	Naples Loveseat, Powered - Black Vinyl.....	938.15	1,031.95	1,313.40	
	830121	Naples Sofa, Powered - Black Vinyl.....	1,079.95	1,187.95	1,511.95	
Powered Tables						
	820950	Ventura Communal Bar Table, Powered - Black.....	889.45	978.40	1,245.25	
	820955	Ventura Communal Bar Table, Powered - White.....	808.40	889.25	1,131.75	
	820964	Ventura Communal Cafe Table, Powered - Black....	582.35	640.60	815.30	
	820965	Ventura Communal Cafe Table, Powered - White....	582.35	640.60	815.30	
	84083	Tech Desk w/ 3 Drawer File Cabinet, Powered - Black Metal.....	638.70	702.55	894.20	
	84084	Tech Desk, Powered - Black Metal.....	560.20	616.20	784.30	
	82076	Sydney Cocktail Table, Powered - Black.....	433.65	477.00	607.10	
	82073	Sydney Cocktail Table, Powered - White.....	433.65	477.00	607.10	
	8202	10' Table, Powered - Black Laminate.....	1,010.00	1,111.00	1,414.00	
	8204	5' Table, Powered - Black Laminate.....	522.00	574.20	730.80	
	8206	8' Table, Powered - Black Laminate.....	1,010.00	1,111.00	1,414.00	
Powered Pedestals						
	85060	Powered Locking Pedestal 36" H, Black.....	510.20	561.20	714.30	
	85061	Powered Locking Pedestal 36" H, White.....	510.20	561.20	714.30	
	85062	Powered Locking Pedestal 42" H, Black.....	608.60	669.45	852.05	
	85063	Powered Locking Pedestal 42" H, White.....	608.60	669.45	852.05	
	820710	Wireless Charging Table, Powered.....	464.65	511.10	650.50	
Midtown Counters & Bars						
	850103	Midtown Powered Counter Unlighted - Pewter.....	1,486.80	1,635.50	2,081.50	
	850102	Midtown Powered Counter Lighted w/ Plug-In - Pewter.....	1,730.45	1,903.50	2,422.65	
	850101	Midtown Bar Unlighted - Pewter.....	1,331.90	1,465.10	1,864.65	
	850100	Midtown Bar Lighted w/ Plug-In - Pewter.....	1,581.80	1,740.00	2,214.50	
DISPLAY & ACCESSORIES						
Product Storage						
	84080	3 Door File Cabinet on Castors - Black	195.00	214.50	273.00	
	85020	Posh Shelving w/ Chrome Frame - White.....	541.10	595.20	757.55	
Refrigerator						
	8503001	Refrigerator - White.....	822.40	904.65	1,151.35	
Lighting						
	850707	Mason Table Lamp - White/Brushed Silver.....	161.90	178.10	226.65	
	850708	Mason Floor Lamp - White/Brushed Silver.....	252.10	277.30	352.95	
Display						
	75030	Display Cube - Black - 12" Small.....	242.35	266.60	339.30	
	75031	Display Cube - Black - 18" Medium.....	285.55	314.10	399.75	
	75032	Display Cube - Black - 24" Large.....	328.75	361.65	460.25	
	72056	Display Counter - Black.....	432.70	475.95	605.80	
	75079	Orion Computer Kiosk - Black.....	432.70	475.95	605.80	

NAME OF SHOW: **New Cardiovascular Horizons Conference / June 2 - 4, 2021**

COMPANY NAME: _____ BOOTH #: _____

CONTACT NAME : _____ PHONE #: _____

E-MAIL ADDRESS : _____

Take advantage of the Online price by ordering at www.freeman.com/store by the deadline date.

Qty	Part #	Description	Online Price	Discount Price	Standard Price	Total
Boxwood Hedges						
_____	85030	7' Boxwood Hedge.....	640.00	704.00	896.00	_____
_____	85035	4' Boxwood Hedge.....	350.00	385.00	490.00	_____
Accessories						
_____	220121	Chrome Stanchion w/ 8' Retractable Belt.....	144.25	158.70	201.95	_____
_____	220118	Chrome Sign Holder.....	103.80	114.20	145.30	_____
_____	750135	Round Literature Rack.....	225.00	247.50	315.00	_____
_____	750136	Flat Literature Rack.....	190.40	209.45	266.55	_____
_____	220109	Chrome Coat Tree.....	69.30	76.25	97.00	_____
_____	220134	Aluminum Easel.....	51.85	57.05	72.60	_____
_____	220110	Chrome Bag Rack.....	112.50	123.75	157.50	_____
_____	10201484	Floor Standing Bulletin Board.....	230.40	253.45	322.55	_____
_____	220106	Corrugated Wastebasket.....	25.05	27.55	35.05	_____
_____	8502	Village Charging Hub.....	254.00	279.40	355.60	_____

Special Drape

Black
 Blue
 White
 Gray
 Red

_____	12103	Special Drape 3'H (per ft.).....	20.75	22.85	29.05	_____
_____	12108	Special Drape 8'H (per ft.).....	26.10	28.70	36.55	_____

TOTAL COST		
_____	+	_____ = _____
Sub-Total		11.45% Tax Total Cost

Taxes: Due to varying taxes across counties and cities for various categories, applicable taxes will be applied to your order accordingly based on the jurisdictions of the show city.

FREEMAN

(888) 508-5054 • Fax (469) 621-5612
 ExhibitorSupport@freeman.com



**ONLINE PRICE
 DISCOUNT PRICE
 DEADLINE DATE
 May 4, 2021**

NAME OF SHOW: **New Cardiovascular Horizons Conference / June 2 - 4, 2021**
 COMPANY NAME _____ BOOTH #: _____
 CONTACT NAME: _____ PHONE #: _____
 E-MAIL ADDRESS _____

For Assistance, please call 888-508-5054 to speak with one of our experts.

For fast, easy ordering, go to www.freeman.com/store

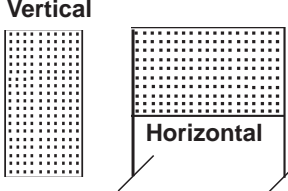
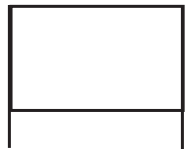
ACCESSORIES

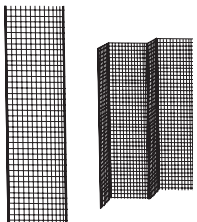
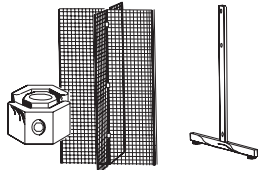
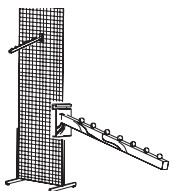
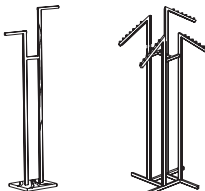
PERFBOARD - SINGLE SIDED 	BULLETIN BOARD 	CHROME GARMENT RACK 	SMALL TICKET TUMBLER 
2' x 8' GRID PANELS 	4 WAY CONNECTORS & GRID LEGS 	7-Ball WATERFALL 	2-WAY STRAIGHT ARM AND 4-WAY SLANT ARM 

Qty	Part #	Description	Online Price	Discount Price	Standard Price	Total	Qty	Part #	Description	Online Price	Discount Price	Standard Price	Total
PERFBOARD / BULLETIN BOARDS							ACCESSORIES						
Please indicate for Perfboard <input type="checkbox"/> Horizontal <input type="checkbox"/> Vertical													
_____	10201280	2'x8'-Perfboard/Single Sided..	121.10	133.20	169.55	_____	_____	10406	Garment Rack.....	126.15	138.75	176.60	_____
_____	10201480	4'x8'-Perfboard/Single Sided..	230.40	253.45	322.55	_____	_____	15905	Fish Bowl.....	43.35	47.70	60.70	_____
_____	10201484	4'x8'-Bulletin Board/Horz.....	230.40	253.45	322.55	_____	_____	159011	Ticket Tumbler - small	130.30	143.35	182.40	_____
_____	1020410	4' x 10" Perfboard Shelf	86.35	95.00	120.90	_____	_____	10404	4-way Slant Arm	155.65	171.20	217.90	_____
_____	10201	Straight Hook	1.15	1.25	1.60	_____	_____	10402	2-way Straight Arm.....	129.75	142.75	181.65	_____
_____	10202	Loop Hook.....	1.35	1.50	1.90	_____	GRIDS						
_____	10203	Single Hook.....	2.70	2.95	3.80	_____	_____	103028	Chrome Grid.....	152.30	167.55	213.20	_____
_____	10204	Double Hook	3.80	4.20	5.30	_____	_____	103029	Grid Legs.....	21.90	24.10	30.65	_____
							_____	10307	7-Ball Waterfall (for grids).....	21.75	23.95	30.45	_____
							_____	103030	4 Way Grid Connectors.....	13.15	14.45	18.40	_____

TOTAL COST		
Sub-Total _____	+ Tax (11.45%) _____	= TOTAL _____

Don't see what you need? Please call Freeman Exhibitor Support at 888-508-5054.

FREEMAN accessories

Take advantage of the Online price by ordering at www.freeman.com/store by May 4, 2021

FROM THE GROUND UP

Engage your audience from the moment they set foot in your exhibit with custom carpets. Our colorfast carpeting boasts a consistent shade every time and the padding exceeds industry standards, ensuring that you'll be floored by the quality. Custom options can be ordered and include borders, patterns and logo applications in both our classic and prestige carpeting lines.

Sustainability Tip:

 DARKER COLORED CARPETS SUCH AS BLACK AND GRAY AND THE TWO-TONED CARPET ARE MADE OF 20-25% RECYCLED CONTENT. RENTING CARPET FROM FREEMAN MINIMIZES YOUR SHIPPING FOOTPRINT.

- Colorfast carpet technology guarantees a uniform and professional look throughout the life of your exhibit
- Diverse customization options guarantee the fulfillment of your brand standards
- All carpet and padding is manufactured with recycled material
- Rental prices are all-inclusive so there are never hidden charges for material handling or pickup
- Renting carpet from Freeman minimizes your shipping footprint.



Call customer service at the number listed on the Quick Facts. For fast, easy ordering, go to freeman.com

PRESTIGE CARPET

Freeman's prestige carpet combines plush comfort with durable soil and stain resistance, perfect for high-traffic areas. Five popular colors are available in a luxurious 40-ounce weight and all nine designer colors are available in a 28-ounce weight.

Freeman's prestige carpet packages include new 10-foot-wide carpet, delivery, Visqueen covering, installation, carpet tape, carpet removal and all carpet material handling fees. Prestige carpet is one time use. The carpet for your booth will be brand new and recycled at the end of the show. Price includes environmentally friendly disposal of carpet after usage. Foam carpet padding is available for a minimal fee. If you have a large order, please contact us to see if volume discounts may apply.

Custom Options

Prestige carpets can also be customized to fit your exhibit needs with unique logos, patterns and borders. Call the phone number on the Quick Facts for assistance.



*Colors available in both 28 oz. and 40 oz.

 **Sustainability Tip:** Prestige carpet is one time use. The carpet for your booth will be brand new and recycled at the end of the show.

CLASSIC CARPET

Custom Cut

Freeman classic carpet is available in a range of colors and includes delivery, Visqueen covering, installation, carpet tape, carpet removal and all carpet material handling fees. Foam carpet padding is available for a minimal fee. If you have a large order, please contact us to see if volume discounts may apply.

Standard Cut

Our classic carpet comes in a variety of sizes. Prices include delivery, installation, carpet tape, carpet removal and all carpet material handling fees. Foam carpet padding and Visqueen covering are available for a minimal fee.

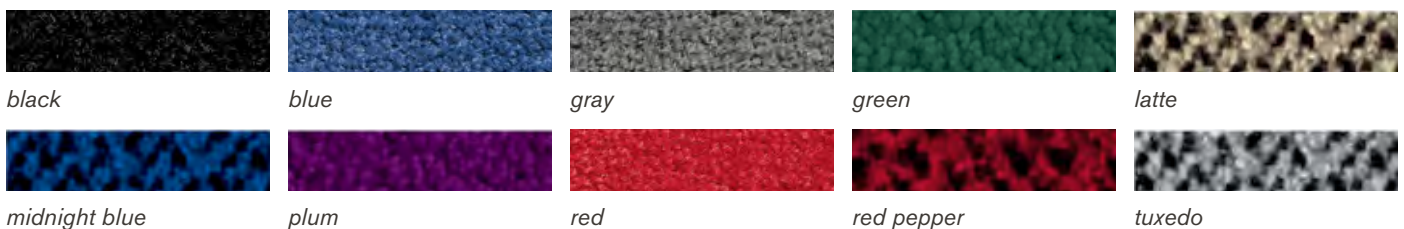

Actual colors may vary slightly

Sustainability Tip: Freeman Classic carpet is reused a minimum of four times before retired from inventory and recycled. Darker colored carpets such as black and gray, as well as the two-toned carpet are made of 20-25% recycled content.

FREEMAN

(888) 508-5054 Fax: (469) 621-5612
 ExhibitorSupport@freeman.com

ONLINE PRICE
 DISCOUNT PRICE
 DEADLINE DATE
 MAY 04, 2021

NAME OF SHOW: **New Cardiovascular Horizons Conference / June 2 - 4, 2021**

COMPANY NAME: _____ BOOTH #: _____

CONTACT NAME : _____ PHONE #: _____

E-MAIL ADDRESS : _____

Take advantage of the Online price by ordering at www.freeman.com/store by the deadline date.

STANDARD SIZE CARPET & PADDING

- Orders received after the deadline date or without payment will be charged the Standard Price and are subject to availability.
- Prestige and Custom Cut Classic Carpet are subject to a 100% Cancellation Charge.
- All utility lines must be installed before carpet installation. Utilities should be ordered in advance.
- All carpet, padding and plastic covering contain recycled content and are recyclable.

10' CLASSIC CARPET , PADDING & PLASTIC COVERING

CHOOSE YOUR CARPET COLOR:

Black Blue Gray Midnight Blue Red Tuxedo

Qty	Description	Online Price	Discount Price	Standard Price	Total
_____	10' x 10' Classic Carpet	\$ 204.05	\$ 224.45	\$ 285.65	_____
_____	10' x 20' Classic Carpet	\$ 408.10	\$ 448.90	\$ 571.35	_____
_____	10' x 30' Classic Carpet	\$ 612.15	\$ 673.35	\$ 857.00	_____
_____	10' x 40' Classic Carpet	\$ 816.20	\$ 897.80	\$ 1,142.70	_____
_____	10' x 10' Carpet Padding - Single Layer.....	\$ 164.30	\$ 180.75	\$ 230.00	_____
_____	10' x 20' Carpet Padding - Single Layer.....	\$ 328.60	\$ 361.45	\$ 460.05	_____
_____	10' x 30' Carpet Padding - Single Layer.....	\$ 492.90	\$ 542.20	\$ 690.05	_____
_____	10' x 40' Carpet Padding - Single Layer.....	\$ 657.25	\$ 723.00	\$ 920.15	_____
_____	10' x 10' Carpet Padding - Double Layer.....	\$ 328.60	\$ 361.45	\$ 460.05	_____
_____	10' x 20' Carpet Padding - Double Layer.....	\$ 657.25	\$ 723.00	\$ 920.15	_____
_____	10' x 30' Carpet Padding - Double Layer.....	\$ 985.85	\$ 1,084.45	\$ 1,380.20	_____
_____	10' x 40' Carpet Padding - Double Layer.....	\$ 1,314.50	\$ 1,445.95	\$ 1,840.30	_____
_____	Plastic Covering (price per sqft).....	\$.50	\$.55	\$.70	_____

CUSTOM CUT CLASSIC CARPET

- Order Custom Cut Classic Carpeting by the sqft if your size is not listed above.

Sample: Booth Size: 10 x 25 = 250 sqft \$ **3.60**

CHOOSE YOUR CARPET COLOR - 16 oz. Carpet:

Black Blue Gray Midnight Blue Red Tuxedo Latte Green Red Pepper

16 oz. Carpet Rental - Price per sqft (100 sqft minimum)

Per sqft	Booth Size: _____ x _____ = _____ sqft	Online Price	Discount Price	Standard Price	Total
		\$ 3.60	\$ 3.95	\$ 5.05	_____

TOTAL COST		
Sub-Total	+	11.45% Tax
		= Total Cost

standard size carpet & padding

FREEMAN

(888) 508-5054 Fax: (469) 621-5612
 ExhibitorSupport@freeman.com

ONLINE PRICE
 DISCOUNT PRICE
 DEADLINE DATE
 MAY 04, 2021

cut to size carpet

NAME OF SHOW: **New Cardiovascular Horizons Conference / June 2 - 4, 2021**

COMPANY NAME: _____ BOOTH #: _____

CONTACT NAME : _____ PHONE #: _____

E-MAIL ADDRESS : _____

Take advantage of the Online price by ordering at www.freeman.com/store by the deadline date.

CUT TO SIZE CARPET & PADDING

- Guaranteed new, high-quality carpet.
- Orders received after the deadline date or without payment will be charged the Standard Price and are subject to availability.
- Prestige and Custom Cut Classic Carpet are subject to a 100% Cancellation Charge.
- All utility lines must be installed before carpet installation. Utilities should be ordered in advance.
- All carpet, padding and plastic covering contain recycled content and are recyclable.

PRESTIGE CARPET *includes plastic covering, delivery, material handling, installation and removal*

CHOOSE YOUR CARPET COLOR - 28 oz. Carpet:

Black Cardinal Charcoal Cream Gray Pearl Navy Toast Wedgewood White

28 oz. Carpet Rental - Price per sq. ft. (100 sqft minimum)

				Online Price	Discount Price	Standard Price	Total
1 - 700 sqft	Booth Size: _____ x _____ = _____ sqft			\$ 5.40	\$ 5.95	\$ 7.55	_____
Over 700 sqft	Booth Size: _____ x _____ = _____ sqft			\$ 5.10	\$ 5.60	\$ 7.15	_____

CHOOSE YOUR CARPET COLOR - 40 oz. Carpet:

Black Charcoal Gray Pearl Navy White

40 oz. Carpet Rental - Price per sq. ft. (100 sqft minimum)

				Online Price	Discount Price	Standard Price	Total
1 - 700 sqft	Booth Size: _____ x _____ = _____ sqft			\$ 5.90	\$ 6.50	\$ 8.25	_____
Over 700 sqft	Booth Size: _____ x _____ = _____ sqft			\$ 5.45	\$ 6.00	\$ 7.65	_____

CARPET PADDING *includes delivery, material handling, installation and removal*

- Order Carpet Padding by the sqft if your size is not listed on the standard size order form.

Sample: Booth Size: 10 x 25 = 250 sq. ft. @ \$ 1.75

Qty	Description	Price per sqft (90 sqft minimum)	Online Price	Discount Price	Standard Price	Total
_____	Carpet Padding -1/2" (90 - 700 sq. ft.)		\$ 1.75	\$ 1.95	\$ 2.45	_____
_____	Carpet Padding-1/2" (Over 700 sq. ft.)		\$ 1.45	\$ 1.60	\$ 2.05	_____
_____	Double Carpet Padding - 1/2" (90 - 700 sq. ft.)		\$ 3.50	\$ 3.85	\$ 4.90	_____
_____	Double Carpet Padding -1/2" (Over 700 sq. ft.)		\$ 2.90	\$ 3.20	\$ 4.05	_____

TOTAL COST		
_____	+	_____
Sub-Total		11.45% Tax
	=	_____
		Total Cost

FREEMAN

(888) 508-5054 Fax: (469) 621-5612
 ExhibitorSupport@freeman.com

cleaning

NAME OF SHOW: **New Cardiovascular Horizons Conference / June 2 - 4, 2021**

COMPANY NAME: _____ BOOTH #: _____

CONTACT NAME : _____ PHONE #: _____

E-MAIL ADDRESS : _____

For fast, easy ordering, go to www.freeman.com/store.

CLEANING SERVICES

- **Cleaning is an exclusive service. This includes all floor services and trash removal.**
- Prices are based on total square footage of booth regardless of area to be cleaned.
- **Show Site Prices will apply to all cleaning orders placed at show site.**

VACUUMING (per sqft - 100 sqft minimum)

Qty (sqft)	Part #	Description	Advance Price	Show Site Price	Total
• Includes emptying of your booth's wastebasket(s) at the time of vacuuming.					
_____	610100	Booth Vacuuming - One Time60	.85	_____
_____	610200	Booth Vacuuming - 2 Days	1.05	1.45	_____
_____	610300	Booth Vacuuming - 3 Days	1.35	1.90	_____
_____	610400	Booth Vacuuming - 4 Days	N/A	N/A	_____

SHAMPOOING (per sqft - 100 sqft minimum)

Qty (sqft)	Part #	Description	Advance Price	Show Site Price	Total
_____	630100	Shampoo Carpet - One Time	1.10	1.55	_____
_____	630200	Shampoo Carpet - 2 Days	1.85	2.60	_____
_____	630300	Shampoo Carpet - 3 Days	2.60	3.65	_____

PORTER SERVICE (per day)

Qty (# days)	Part #	Description	Advance Price	Show Site Price	Total
• Includes emptying of your booth's wastebasket(s) and policing of your exhibit area at two-hour intervals during show hours.					
_____	620500	Exhibit Area / Under 500 sqft.	117.00	163.80	_____
_____	6201500	Exhibit Area / 501 - 1,500 sqft.....	136.45	191.05	_____
_____	6202500	Exhibit Area / 1,501 - 2,500 sqft.....	159.00	222.60	_____
_____	6203500	Exhibit Area / Over 2,500 sqft.....	Call for Quote		

TOTAL COST				
_____	+	_____	=	_____
Sub-Total		11.45 %Tax		Total Cost

FIT TO PRINT

SmartFabric® is a triple-layered fabric made of 100 percent polyester that's ideal for printed graphics. It's an extremely versatile all-in-one fabric and has been treated to meet NFPA 701 small-scale flammability standards. This lightweight material provides an easy way to make a big impact and has a small shipping footprint to reduce your shipping cost and carbon emissions.



* Client to provide print-ready artwork, or Freeman can design artwork for an additional fee.

SMARTFABRIC® RENTAL EXHIBITS



10 x 10 ft. unit

GRAPHIC SIZE

116"W 92.5"H



10 x 20 ft. unit

GRAPHIC SIZE

233.5"W 92.5"H

RENTAL EXHIBITS INCLUDE:

- Custom Fabric Graphic* with zippered carrying case (fabric graphic purchased to keep)
- Rental Frame, a 100% recyclable structure
- 9' x 10' or 9' x 20' Classic Carpet (color selections on page 3)
- Exhibit Installation & Dismantle
- Exhibit Material Handling
- Nightly Vacuuming
- 3 Arm Lights per 10' Booth
- 6 Arm Lights per 20' Booth
- Power for lights only

FRAME ONLY UNIT

If you rented a SmartFabric booth previously, you own the graphic. For subsequent shows, all you need to do is rent the frame. We will install your fabric graphic over the frame.**

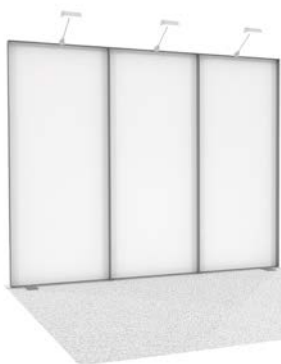

10 x 10 ft. frame

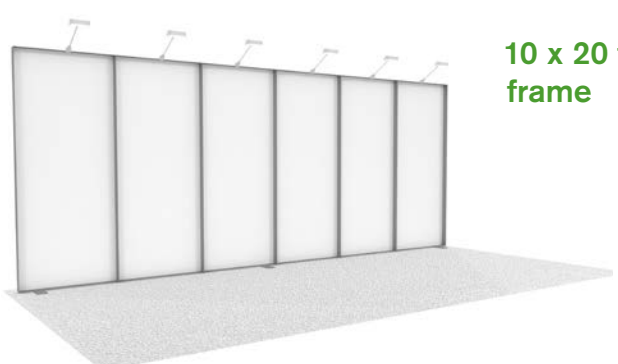

10 x 20 ft. frame

RENTAL EXHIBITS INCLUDE:

- Rental Frame
- 9' x 10' or 9' x 20' Classic Carpet (color selections on page 3)
- Exhibit Installation & Dismantle
- Exhibit Material Handling
- Nightly Vacuuming
- 3 Arm Lights per 10' Booth
- 6 Arm Lights per 20' Booth
- Power for lights only

*Client to provide print-ready artwork, or Freeman can design artwork for an additional fee. **Only Freeman SmartFabric will be installed on the frame.

CLASSIC CARPET

Freeman Classic carpet is reused a minimum of four times before being retired from inventory and recycled. Darker-colored carpets such as black and gray, as well as two-toned carpets, are made of 20-25 percent recycled content.

9' x 10' or 9' x 20' (16 oz.) – Color Options Included with Rental Package Options

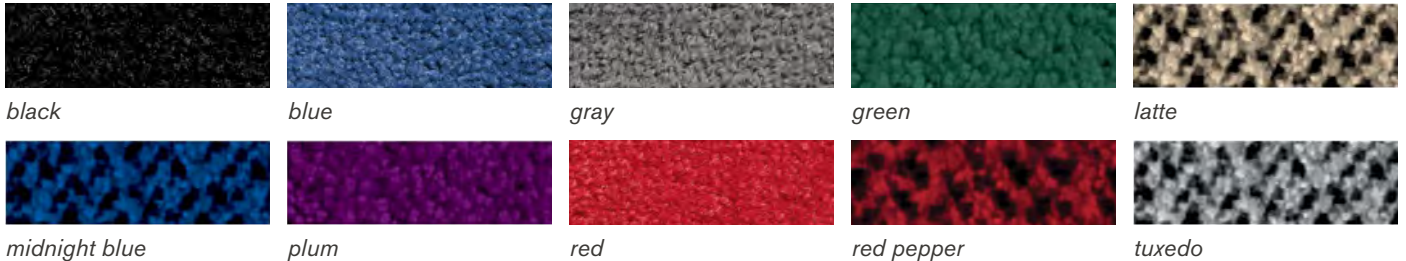

9' carpet is laid toward the front edge, leaving 1' at the back of the booth for utility port access. Actual colors may vary slightly.

PRESTIGE CARPET

Prestige carpet is for one time use. The carpet for your booth will be brand new and recycled at the end of the show. Renting carpet from Freeman minimizes your shipping footprint.

(28 oz.) – Available Upgrade Color Options

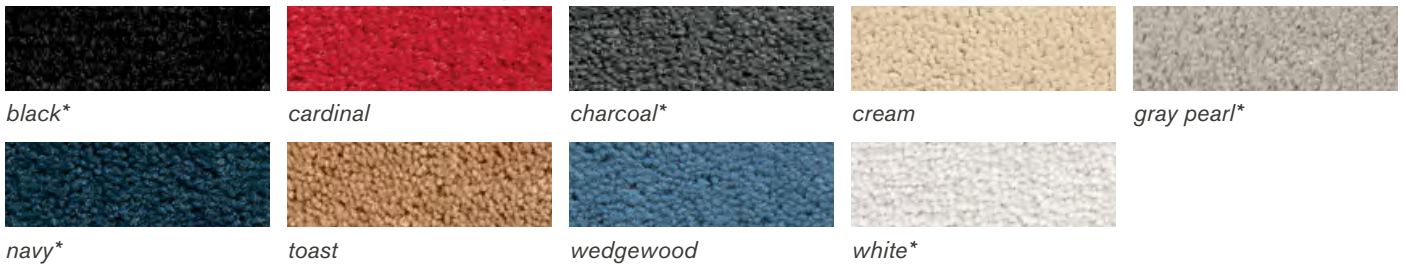

*Colors available in both 28 oz. and 40 oz. Actual colors may vary slightly.

OPTIONAL ACCESSORIES

SMARTFABRIC® ZIPPERED CARRYING CASE

20"W | 8"H | 16"D

One SmartFabric zipper bag is included with purchase.



CLEAR ACRYLIC SHELF

36"W | .25"H | 12"D

(holds up to 15 lbs each)



CUSTOM GRAPHICS

An exhibitor sales specialist will contact you to review the process for providing your own graphic files or options for using our graphic design services to design your back wall.

FREEMAN SUSTAINABILITY FOCUS

 This solution is a clean footprint booth. This rental unit includes a 100 percent recyclable aluminum frame. All flooring, lighting, furniture, and booth structure will go back into inventory to be reused or recycled.

FREEMAN

(888) 508-5054 Fax: (469) 621-5612
 ExhibitorSupport@freeman.com

DISCOUNT PRICE
 DEADLINE DATE
 MAY 04, 2021

smartfabric

NAME OF SHOW: **New Cardiovascular Horizons Conference / June 2 - 4, 2021**

COMPANY NAME: _____ BOOTH #: _____

CONTACT NAME: _____ PHONE #: _____

E-MAIL ADDRESS: _____

For fast, easy ordering, go to www.freeman.com/store.

SMARTFABRIC EXHIBIT

SmartFabric Exhibits provide a custom printed fabric graphic to keep and reuse on future events.



SmartFabric Rental Exhibit Includes:

- 116.5" X 92.5" Custom Fabric Graphic (Purchased item to keep)
- Carrying Case for Graphic (To carry the purchased fabric graphic)
- Classic Carpet 10' X 10' or 10' X 20' (Select color below)
- Installation & Dismantle of Exhibit
- Material Handling of Exhibit
- Nightly Vacuuming
- 3-Arm Lights (per 10 ft.)
- Power for LIGHTS only

- Classic Carpet: Black Blue Gray
 Midnight Blue Red Tuxedo

Qty	Description	Discount	Standard	Total
_____	10' x 10' SmartFabric Exhibit.....	\$ 2,801.50	\$ 3,922.10	_____
_____	10' x 20' SmartFabric Exhibit.....	\$ 5,401.50	\$ 7,562.10	_____

CUSTOM GRAPHICS

A Freeman Exhibitor Support Specialist will be contacting you to review the process for providing graphic files and helpful tips that will ensure a successful graphic print.

FRAME ONLY UNIT

The SmartFabric frame only unit is for exhibitors who have previously rented the SmartFabric exhibit (above) and have the fabric graphic ready for reuse. If you need a new graphic made, please select the SmartFabric Rental Exhibit (above). No fabric graphics will be printed without the rental unit.



Frame Only Unit Includes:

- Classic Carpet 10' X 10' or 10' X 20' (Select color below)
- Installation & Dismantle of Exhibit
- Material Handling of Exhibit
- Nightly Vacuuming
- 3-Arm Lights (per 10 ft.)
- Power for LIGHTS only
- Where is your fabric coming from?:
 Bringing to show site
 In Freeman storage

- Classic Carpet: Black Blue Gray
 Midnight Blue Red Tuxedo

Qty	Description	Discount	Standard	Total
_____	10' x 10' Frame Only Unit.....	\$ 1,833.00	\$ 2,566.20	_____
_____	10' x 20' Frame Only Unit.....	\$ 3,055.00	\$ 4,277.00	_____

ACCESSORIES

Qty	Description	Discount	Standard	Total
_____	SmartFabric Arm Light	\$ 65.00	\$ 91.00	_____
_____	SmartFabric Acrylic Shelf (supports up to 15 lbs).....	\$ 150.00	\$ 210.00	_____
_____	SmartFabric Carrying Case (purchase).....	\$ 20.00	\$ 28.00	_____

QUICK TIPS

• Orders received after the deadline or without payment will be charged the Standard price and are subject to availability. All graphics are subject to a 100% cancellation charge once production begins.

The product offered has recyclable content or has eco-friendly attributes and is 100% recyclable according to manufacturer's specifications.

TOTAL COST		
_____	+	_____ = _____
Sub-Total	11.45 % Tax	Total Cost

SEEING IS BELIEVING

.....

Quality graphics contribute significantly to the impact of your exhibit. With state-of-the-art design and printing capabilities, Freeman brings your banners, signage, and exhibit graphics to life in a larger-than-life way. Our graphics products redefine “high definition,” which means your brand has never been seen like this before.

- Photo-quality / high-resolution printing on a variety of rigid and rolled material including honeycomb, foam, Polyfoam, PVC, acrylic, fabric, vinyl and mesh materials
- Grand Format printers provide high-resolution digital printing of single and double-sided banners in virtually any size
- Electronic file transfer, in-house printing, and company-wide procedure standardization allow us to control quality, cost and scheduling on a nationwide basis
- Extensive resources ensure that last minute repairs and replacements are handled efficiently as needed, no matter where your event may be located



Call customer service at the number listed on the Quick Facts. For fast, easy ordering, go to freeman.com

CREATING VISUAL EXCITEMENT

Quality graphics contribute significantly to the impact of your exhibit. Vivid colors and sharp images attract attention, build traffic, and communicate messages more effectively. Freeman has invested in the latest printing technology and has the skills to provide you with the finest high-resolution digital graphic reproduction available.

STATE-OF-THE-ART CAPABILITIES

Freeman can provide four-color, photo-quality, high-resolution digital printing in virtually any size for banners, signage, exhibit graphics, and more. Each Freeman location has stand-alone printing capabilities, along with two additional graphic locations for additional support and for special requirements.

SUPERIOR QUALITY CONTROL

Electronic file transfer, in-house printing, and company-wide standardization of procedures allow us to control quality, cost and scheduling for our customers on a nationwide basis. Last minute repairs and replacements are handled efficiently through our nationwide resources.

DEPTH OF RESOURCES

- 5M UV roll printers provide grand format, four-color, high-resolution digital printing of single and double-sided banners up to 16' wide and virtually any size with seams.
- 3M Dye Sublimation printers provide 10' fabric graphics that work perfectly in our SmartWall panel system.
- UV flatbeds print directly to a variety of ridged materials and offer a 100% recyclable graphic when using a cardboard substrate.
- Freeman offers 100% recyclable substrates that can save you money and the environment.
- Large format Eco-Solvent printers produce high quality graphics for wall, carpet and window applications.
- 3M high speed digital cutters allow for precise cutting of multiple panel applications and also custom router graphic panels.
- Computer-aided graphic design & layout available for your assistance.

REPRODUCTION AND INSTALLATION

- Suspended banners
- Accent graphic photo panels
- Large format signage and banners
- Logo reproduction
- Backlit displays and murals
- Four-color carpet image printing



FREEMAN

(888) 508-5054 Fax: (469) 621-5612
 ExhibitorSupport@freeman.com

DISCOUNT PRICE
 DEADLINE DATE
 MAY 04, 2021

NAME OF SHOW: **New Cardiovascular Horizons Conference / June 2 - 4, 2021**

COMPANY NAME: _____ BOOTH #: _____

CONTACT NAME: _____ PHONE #: _____

E-MAIL ADDRESS: _____

For fast, easy ordering, go to www.freeman.com/store.

GRAPHICS

To order your graphics, complete this order form and attach your sign copy or electronic file.
 Please see artwork guidelines for electronic files on page 2 of this form.
Note: All graphics are subject to a 100% Cancellation Charge.

DIGITAL GRAPHICS

Freeman has the capabilities to provide you with the finest digital graphic reproduction available. Capabilities include four-color, photo-quality, high-resolution digital printing virtually any size for banners, signage, exhibit graphics and more.

_____ L X _____ W = _____ sqft

_____ sqft \$ 24.70 per sqft discount price
 x or = \$ _____
 \$ 37.05 per sqft standard price

- Minimum order per graphic 9 sqft (1296 sqin)
- Double sqft for double-sided graphics
- Round sqft to next whole increment
- File conversion, retouching, cloning or color correcting may incur additional labor charges. (See reverse side for graphic guidelines.)

LARGE DIGITAL GRAPHICS

Please call an Exhibitor Sales Specialist for price quotes on graphics over 80 sqft.

File Information:
 Electronic File Name _____

Application _____

PMS Colors _____

Backing Material:

- | | |
|---|---|
| <input type="checkbox"/> Freeman Foam (Foamcore) | <input type="checkbox"/> Masonite |
| <input type="checkbox"/> Freeman PVC (PVC) | <input type="checkbox"/> Plexi |
| <input type="checkbox"/> Freeman HD Foam (Gatorfoam) | <input checked="" type="checkbox"/> Freeman Honeycomb (Eco-Board) |
| <input type="checkbox"/> Freeman Polyfoam (Ultra Board) | <input type="checkbox"/> Other |

The product offered has recycled content or has eco-friendly attributes and is 100% recyclable according to the manufacturer's specifications.

Vertical Horizontal Use Your Judgment For Sign Layout

Special Instructions _____

STANDARD SIZES

CHOOSE YOUR SIZE:

QTY.	Discount Price	Standard Price	TOTAL
7" x 11"	56.55	84.85 =	_____
7" x 22"	60.70	91.05 =	_____
7" x 44"	68.85	103.30 =	_____
9" x 44"	80.15	120.25 =	_____
11" x 14"	60.70	91.05 =	_____
14" x 22"	84.95	127.45 =	_____
14" x 44"	97.90	146.85 =	_____
22" x 28"	130.70	196.05 =	_____
28" x 44"	176.20	264.30 =	_____
20" x 60"	240.35	360.55 =	_____

(white only)

Note: File conversion, retouching, cloning or color may incur additional labor charges. (See reverse side for graphic guidelines.)

INDICATE YOUR SIGN COPY HERE:

* Please feel free to attach additional sign copy on separate page.

Vertical Horizontal Use Your Judgment For Sign Layout

Background Color: _____

Lettering Color: _____

TOTAL COST		
Sub-Total	+	11.45 % Tax = Total Cost

CUSTOMER GUIDELINES FOR SUBMITTING GRAPHICS ARTWORK

Our goal is to provide you with the best possible quality graphics for your event or exhibit. You can help us in that effort by providing digital art files using the following guidelines. If you are sending us completed, print-ready files, please pass the following information on to your graphics designer or art department. Artwork must be submitted in the proper resolution and/or file size to produce quality images. Please provide proper color matching information and proofs to ensure accurate color reproduction.

PLEASE PROVIDE THE FOLLOWING WHEN SUBMITTING ART

RASTER ART (photos, logos containing any continuous tone images):

- Art submitted at 1:1 (100%), resolution should be no less than 60 dpi (100 dpi preferred)
- Art submitted at 2:1 (50%), resolution should be no less than 120 dpi (200 dpi preferred)
- Art submitted at 4:1 (25%), resolution should be no less than 240 dpi (400 dpi preferred)

VECTOR ART:

- Logos should be vector and have outlined fonts (if provided as bitmap, please use high-res images)

FONTS and LINKS

- Supply all fonts used in your design (zip Mac fonts). If unsure how to collect fonts, convert them to outlines
- Supply all links used in your document. Use packaging feature if available. If unsure how to collect links, embed them in the file when saving.

COLOR

- If PMS color matching is required, please use original Pantone + Solid Coated swatches in your artwork. Modifying Pantone names will result in printing default color (CMYK)
- CMYK artwork will be produced "As Is". Our color output is balanced and vibrant.
- Convert RGB art to CMYK if possible.
- If you are sending Certified Color Proofs (Gracol, Swop, Fogra), please provide ICC file information used to print your samples. Best option would be to include ICC chart on your prints.

ARTWORK IN THE STRUCTURE

- Please note that any panels going in the metal frame will hide 1/4" of your art all the way around. If you have a continuous wall where individual panels are divided by metal, use 1.25" spacing in between each panel to account for gaps and the natural flow of the graphics.

ACCEPTABLE FILE SOFTWARE

We are capable of working with both PC and MAC based software, and can accept art created with the ADOBE Creative Suite - Illustrator, InDesign, and Photoshop

Always provide the following:

- Native files with fonts and links (zipped)
- High-res PDF-X/4 exports of the files

ACCEPTABLE FILE TYPES and SUPPORT FILES

NATIVE FILES:

- AI CLOUD (CC) file with Packaged supporting links and fonts. You may keep images linked but Packaging feature must be used.
- AI (CS6, CS5, CS4...) file with embedded links and outlined fonts
- EPS file with embedded links and outlined fonts
- INDD file with Packaged supporting links and fonts

PRINT FILES:

- High-res PDF-X/4 (preferred)
- AI with PDF content (choose this option when saving file)
- EPS files with embedded links and outlined fonts

RASTER OR BITMAP ART:

- Photoshop EPS (preferred, use 8-bit preview, Max, Quality JPG compression)
- PSD (make sure font layers are rasterized)
- TIFF, JPG (quality 8 and higher)

Mac users: Use Zip or Stuffit programs when submitting fonts other than OTF (Open Type Fonts)

WAYS TO SEND ARTWORK

• Files below 10 MB can be delivered via email. Larger files may be posted to Freeman's FTP site. You may get the password and other needed information from your Freeman service representative in order to post files. However, a hard copy proof and backup of the files on CD-Rom/DVD may be required to be sent via overnight delivery in addition to posting the electronic files. Please call (888) 508-5054 for assistance.

LABOR JURISDICTIONS / NEW ORLEANS

To assist you in planning for your participation in your New Orleans show, we are certain you will appreciate knowing in advance that union labor may be required for certain aspects of your exhibit handling. To help you understand the jurisdiction the various unions have, we ask you to read the following:

LABOR SOURCE

We currently have a labor agreement with Central South Carpenters Regional Council to provide labor for display installation and dismantling. Full time employees of the exhibiting companies, however, may set their own exhibits without assistance from the local. Any labor services that may be required beyond what your regular full time employees can provide, must be rendered by the local. Labor can be ordered in advance by returning the Display Labor order form, or on show site, at the Freeman Service Desk.

MATERIAL HANDLING

Exhibitors may hand-carry their own materials into the exhibit facility. The use or rental of dollies, flat trucks and other mechanical equipment; however, is not permitted. Freeman will control access to the loading docks in order to provide for a safe and orderly move in/out.

TIPPING

Freeman requests that exhibitors do not tip our employees. They are paid at an excellent wage scale denoting a professional status, and we feel that tipping is not necessary. This applies to all Freeman employees. Any request for such should be brought to the attention of a representative at the Freeman Service Desk or correspondence may be directed to the attention of the General Manager at the local office address.

SAFETY

Standing on chairs, tables or other rental furniture is prohibited. This furniture is not engineered to support your standing weight. Freeman can not be responsible for injuries or falls caused by the improper use of this furniture. If assistance is required in assembling your booth, please order labor on the Display Labor order form and the necessary ladders and tools will be provided.

LET US DO THE HEAVY LIFTING

Freeman specialists are ready to assist you with all of your exhibit requests, from beginning to end. And when it comes to installing and dismantling exhibits, we make no exceptions. Whether it's shipping and storage, emergency on-site repairs, basic installation and dismantling or support service coordination, including electrical, furnishings and more, Freeman has the resources and capabilities to ensure the most successful show experience possible.



Call customer service at the number listed on the Quick Facts. For fast, easy ordering, go to www.freeman.com

Freeman installation & dismantling experts work closely with you to coordinate every phase of your trade show participation, including:

- Pre-planning and budget consultation
- Skilled labor coupled with support services coordination - electrical, furnishings, floral, transportation, and audio visual
- On-site supervisors with dedicated floor managers
- Full, in-house carpentry for emergency repairs and refurbishing
- Post-show evaluations focused on incremental improvement to meet rapidly changing market conditions based upon customer feedback
- Post-show evaluations that help identify small changes that make big impacts

ON-SITE SUPERVISION

You may wish to supervise labor on your own, but if you need assistance, Freeman installation & dismantling experts will get the job done as an extension of your team.

If You Use Freeman Staff

Exhibits can be set up prior to your arrival under the direction of Freeman I&D supervisors.



01/17 | 55774

FREEMAN

(888) 508-5054 • Fax (469) 621-5612

ExhibitorSupport@freeman.com

NAME OF SHOW: **New Cardiovascular Horizons Conference / June 2 - 4, 2021**

COMPANY NAME _____ BOOTH #: _____

CONTACT NAME: _____ PHONE #: _____

E-MAIL ADDRESS _____

For Assistance, please call 888-508-5054 to speak with one of our experts.

For fast, easy ordering, go to www.freeman.com/store

DISPLAY LABOR (One Hour Minimum per Worker)

Description Site		Advance	Show Price
Straight Time- 8:00 A.M. to 5:00 P.M. Monday through Friday		\$ 109.50	\$ 153.50
Overtime- 5:00 P.M. to 8:00 A.M. Monday through Friday and all day Saturday and Sunday		\$ 164.25	\$ 230.00
Double Time- Holidays		\$ 219.00	\$ 306.75

- Show Site prices will apply to all labor orders placed at show site.
- Price is per person/per hour.
- Start time guaranteed only at start of working day.
- One hour minimum per person - labor thereafter is charged in half (1/2) hour increments.
- Labor must be canceled in writing, 24 hours in advance to avoid a one (1) hour cancellation fee per worker.
- When scheduling dismantle labor, be sure to allow sufficient time for empty containers to be returned to your booth.
- Freeman supervised jobs will be completed at our discretion prior to show opening and before the hall must be cleared. **Please include setup plan/photo, special instructions & inbound shipping information with this order.**

INSTALLATION LABOR

Freeman Supervised Labor - Please complete the reverse side of this form.

- Installation of your exhibit will be completed at our discretion prior to show opening.
- The charge for this service is 30% of the total installation labor bill, with a minimum of \$45.00.

Emergency contact: _____ Phone Number: _____

Exhibitor Supervised Labor (Supervisor must check in at the Freeman Service Center to pick up labor)

Supervisor will be: _____ Phone Number: _____

Date	Start Time	No. of People	Approx. Hrs. per Person	Total Hrs.	Hourly Rate	Estimated Total Cost
_____	_____	_____	x _____ = _____	@ \$ _____ = \$ _____		
_____	_____	_____	x _____ = _____	@ \$ _____ = \$ _____		
_____	_____	_____	x _____ = _____	@ \$ _____ = \$ _____		
Freeman Supervision (30%/\$45.00)						= \$ _____
2% Tax						= \$ _____
Total Installation						= \$ _____

DISMANTLE LABOR

Freeman Supervised Labor - Please complete the reverse side of this form.

- Freeman is not responsible for product or literature that is not properly packed and labeled by exhibitor.
- The charge for this service is 30% of the total dismantle labor bill, with a minimum of \$45.00.

Emergency contact: _____ Phone Number: _____

Exhibitor Supervised Labor (Supervisor must check in at the Freeman Service Center to pick up labor)

Supervisor will be: _____ Phone Number: _____

Date	Start Time	No. of People	Approx. Hrs. per Person	Total Hrs.	Hourly Rate	Estimated Total Cost
_____	_____	_____	x _____ = _____	@ \$ _____ = \$ _____		
_____	_____	_____	x _____ = _____	@ \$ _____ = \$ _____		
_____	_____	_____	x _____ = _____	@ \$ _____ = \$ _____		
Freeman Supervision (30%/\$45.00)						= \$ _____
2% Tax						= \$ _____
Total Dismantle						= \$ _____

FREEMAN installation & dismantle labor

NAME OF SHOW: **New Cardiovascular Horizons Conference / June 2 - 4, 2021**
COMPANY NAME: _____ BOOTH#: _____
CONTACT NAME: _____ PHONE#: _____

FREEMAN SUPERVISED LABOR

IN ORDER TO BETTER SERVE YOU - PLEASE COMPLETE THE FOLLOWING INFORMATION IF YOUR DISPLAY IS TO BE SET-UP AND/OR DISMANTLED BY FREEMAN I&D AND YOU WILL NOT BE PRESENT TO SUPERVISE THE INSTALLATION AND/OR DISMANTLE.

INBOUND SHIPPING & SET UP INFORMATION

Freight will be shipped to Warehouse _____ Show Site _____ Date Shipped _____
Setup Plan/Photo: Attached _____ To Be Sent With Exhibit _____ In Crate No. _____
Carpet: With Exhibit _____ Rented From Freeman _____ Color _____ Size _____

Electrical Placement: Drawing Attached _____ Drawing With Exhibit _____ Electrical Under Carpet _____
Comments: _____

Graphics: With Exhibit _____ Shipped Separately _____
Comments: _____

Special Tools/Hardware Required: _____

OUTBOUND SHIPPING INFORMATION

SHIP TO: _____

METHOD OF SHIPMENT

- Freeman Exhibit Transportation:**
 - Common Carrier
 - Air Freight Next Day 2nd Day Deferred Expedited
- Other (list carrier name & phone number):**
 - Other Common Carrier: _____
 - Other Air Freight: _____
 - Van Line: _____

FREIGHT CHARGES

- Prepaid Collect
- Bill To: _____

In the event your selected carrier fails to show on final move-out day, please select one of the following options:

- Reroute via Freeman's choice
- Deliver back to Freeman warehouse at Exhibitor's expense.

PLEASE NOTE: Freeman is not responsible for product or literature that is not properly packed and labeled by exhibitor.

FREEMAN installation & dismantle labor



(O) 904.513.1370 | (F) 337.993.7922
 sales@m3meet.com | www.m3meet.com

Exhibit Audiovisual Services Form

E-mail completed order form to sales@m3meet.com or fax to 337.993.7922. Upon receipt of order form, an invoice will be sent to the email address provided below with online credit card payment options. Prices are inclusive for the duration of the event.

DIGITAL DISPLAYS

	Price	Quantity	Total
60" HDTV <i>(includes 60" HDTV, adjustable stand with cover, HDMI or SVGA cable from computer to TV, extension cord, power strip and labor for set and strike)</i>	\$1,950		
55" Touch Screen Interactive Monitor <i>(includes 55" HD touch screen monitor, adjustable stand with cover, HDMI or SVGA cable from computer to TV, extension cord, power strip and labor for set and strike)</i>	\$3,500		
50" HDTV <i>(includes 50" HDTV, adjustable stand with cover, HDMI or SVGA cable from computer to TV, extension cord, power strip and labor for set and strike)</i>	\$1700		
40" HDTV <i>(includes 40" HDTV, adjustable stand with cover, HDMI or SVGA cable from computer to TV, extension cord, power strip and labor for set and strike)</i>	\$1,500		
24" HDTV <i>(includes 24" computer monitor for table top, HDMI or SVGA cable from computer to monitor, extension cord, power strip and labor for set and strike)</i>	\$675		

COMPUTERS

	Price	Quantity	Total
PC Laptop with MS PowerPoint	\$475		
MAC Laptop with Keynote or MS PowerPoint	\$650		
Apple iPad/Android Tablet	\$225		

SPECIALTY ITEMS

	Price	Quantity	Total
Color Laser Multi-Function Printer/Scanner	\$700		
25' Extension Cord with Power Strip	\$50		
25' HDMI Video Cable or SVGA Computer Cable	\$40		
PC, MAC or Tablet Adaptors <i>(Display Port, Thunderbolt or Lightning Adaptors)</i>	\$40		
Order Total		\$	

[Fair market value replacement fee will be charged for items not returned.]

Additional products and services available upon request.

CUSTOMER INFORMATION

Name:
Company:
Mobile:
E-mail:
Booth Number:

Services do not include hotel electrical or internet connection charges.



Royal Productions
ENGAGE ♦ EDUCATE ♦ ENTERTAIN

Please return order to: eventtechnology@royalproductions.com

Effective Date: 2.1.2019

Company Name	
Contact Name	
Address	
City, State, Zip	
Contact Cell	
Contact Fax	
Contact E-Mail	

Confirmation #	
Room or Booth	
Set Up Date/Time	
Removal Date/Time	

Accepted Credit Cards are VISA, Mastercard, & American Express

Card Type		Amount	
Card Number		Exp Date	
Name on Card		Signature	

The credit card listed above will be used for all charges, in advance and on-site. **Orders must be received 10 days prior to power set up to receive the advance rate.** Cancellations must be received 48 hours prior to set up, to receive refund. Charges to Group Master Account can be arranged through the Convention Services Department.

All items below are a one time event charge

Dedicated Outlets	Advance Rate	Quantity	Normal Rate	Quantity	Total
** Labor is included in the price of each item below **					
15a 120v outlet	\$132		\$172		\$ -
20a 120v outlet	\$198		\$257		\$ -
Rental Items					
Power Strip	\$24		\$32		\$ -
25' Extension Cord	\$30		\$40		\$ -

Electric Services	Advance Rate	Quantity	Normal Rate	Quantity	Total
** Each item below requires a 2 hr minimum set & 2 hr minimum strike labor fee. Please see rates below**					
** 30a 208v single phase	\$432		\$562		\$ -
** 60a 208v single phase	\$720		\$936		\$ -
** 60a 208v 3 phase	\$880		\$1,145		\$ -
** 100a 208v 3 phase	\$1,260		\$1,638		\$ -
** 200a 208v 3 phase	\$2,100		\$2,745		\$ -
** Aut 4 50' Camlock set	\$300		\$390		\$ -
** Bare wire disconnect	\$180		\$235		\$ -
Rental Items					
Power Distro (100a / 200a)	Call for Pricing				
** Electrical Set Labor Hours (as per rates below)					\$ -
** Electrical Strike Labor Hours (as per rates below)					\$ -

Labor Rates are as follows:
Normal Hours: Monday - Friday (7:30 AM - 3:30 PM): \$150.00 /hr
After Normal Hours & Saturdays: \$180.00 / hr
Sundays & Holidays: \$220.00 / hr

All emergency calls with have a 4 Hr Min (Monday- Saturday with less than 24hrs notice; Sundays and holidays with less than 48hrs notice)

Subtotal	\$	-
Labor	\$	-
Convention Center Tax 2%	\$	-
State & CityTax 9.45%	\$	-
25% Service Charge	\$	-
Total	\$	-

Bare wire tie ins require a disconnect box. Standard tie in method is Camlock (100a - 400a) or Hubbel Twist Lock (30a - 60a). All feeder cable must be provided by Royal Productions. Services typically remain active throughout the duration of the event.

For some conditions, particularly Exhibitor Setups, the cords must be suspended above the walkway by means of a truss system. These conditions are:
• Where any area has more than six of the 15- or 20-amp circuits
• Where it's necessary to cross a walkway to provide more than six of the 15- or 20-amp circuits to any area
• Where power requirements are for anything larger than the 15- or 20-amp circuits (camlocks, 30-amp circuits, etc.)

Please attach any Complex or Specific installation instructions, diagrams, and scheduling with your order. Our service representative will contact you to discuss your particular needs, and insure order accuracy.

Please contact us at eventtechnology@royalproductions.com or 504-335-3118 if you have any questions.

Customer Signature and Date

Comments and items not listed.

LEAD RETRIEVAL 101

How are you capturing and following up with all of the leads collected at your booth?

“Maximize your ROI by using ATS Lead Retrieval services.”

Badges at events act as a form of identification and most importantly, electronic business cards. In an effort to streamline session attendance tracking & exhibitor lead capture show managers incorporate QR barcodes fully encoded with attendee contact info as well as important demographic data allowing the exhibitors to easily qualify and follow up.

.....

Why use event provided Lead Retrieval services?

- Easy to scan & capture attendee contact + key demographic information.
- Digital qualifiers & note taking
- Lead data available in real-time & post event (saved in Cloud for up to 18 months)
- Onsite technical support included
- Easily manage your exhibit booth team's leads
- Customization and seamless integrations into your existing CRM system available.



Dedicated device to capture leads
Just Point & Scan

MobilePlus™



Large format device to capture leads
Just Walk Up & Scan

Self Scan Plus™



Use your own device to capture leads
Just Point & Scan

LeadsPlus™ App

ATS AMERICAN TRADESHOW SERVICES

LEAD RETRIEVAL ORDER FORM DISCOUNT DEADLINE: FRIDAY, MAY 7, 2021

Click here to ORDER ONLINE

- Instantly capture attendee contact info! Just **"Point and Scan"** the badges QR Code
- Personalize Leads by using our **"Custom Qualifiers"** with the ability for note taking
- Real-time lead data & analytics make following up a breeze; easy and efficient
- Leads stored in the cloud for up to 18 months

MOST POPULAR

Handheld "State of the Art" Honeywell Scanner

MobilePlus™

Social Distancing Option

Use our Surface Pro and Stand Alone Scanner

Self Scan Plus™

Use your own IOS or Andoid Devices

LeadsPlus™ App

ITEM	DIS. DEADLINE	SHOW RATE	QTY	SUBTOTAL
Mobile Plus	\$ 369.00	\$ 419.00	_____	\$ _____
Self Scan Plus	\$ 899.00	\$ 949.00	_____	\$ _____
LeadsPlus App (First License)	\$ 359.00	\$ 409.00	_____	\$ _____
LeadsPlus App (Additional License)	\$ 99.00	\$ 149.00	_____	\$ _____
LeadsPlus App Bundles:				
3 Pack	\$ 499.00	\$ 549.00	_____	\$ _____
6 Pack	\$ 799.00	\$ 849.00	_____	\$ _____
10 Pack	\$ 999.00	\$ 1049.00	_____	\$ _____
Mobile Plus Add-Ons:				
		Post Dis. Deadline		
Z-Printer Plus	\$ 75.00	\$ 95.00	_____	\$ _____
Custom Survey	\$ 60.00	\$ 80.00	_____	\$ _____
Delivery & Setup	\$ 65.00	\$ 85.00	_____	\$ _____

(PLEASE PRINT) BOOTH NO. _____

COMPANY _____

EMAIL(S) _____

ADDRESS _____

CITY, STATE, ZIP, COUNTRY _____

ORDER CONTACT _____

PHONE NO. _____

ONSITE CONTACT _____

ONSITE CELL PHONE _____

CREDIT CARD NO.:

CARDHOLDER NAME: _____

EXPIRATION DATE: _____ / _____ SECURITY CODE: _____

CARDHOLDER SIGNATURE: _____

Click here to ORDER ONLINE

Username: NCVH2021 | Password: 1521

Sub-Total = \$ _____

ADD - New Orleans Sales Tax 9.45% _____

Total Due (in US Funds) = \$ _____

Visit Us at: www.american-tradeshow.com Email Orders to: orders@american-tradeshow.com

Questions? Please call: 985-240-5507 Fax: 985-809-1888

Mail Checks to: ATTN - American Tradeshow Services | 217 General Patton Ave. Mandeville, LA 70471